

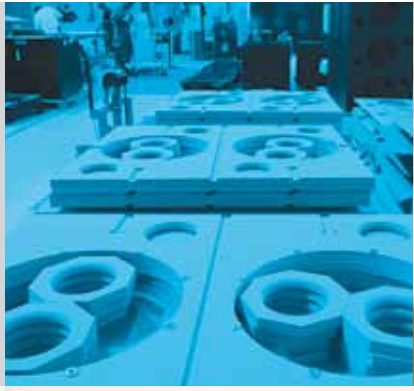

FULL LINE CATALOG WINTER|SPRING 2011

# The Art of Audio



The  
Power of  
Technology

The  
Advantage of  
Integrated  
Systems





Live sound is at its best when the audio system reproduces the source with nuance, power and accuracy, allowing the listeners to focus on the performance without even being conscious of the processors, amplifiers and loudspeakers that make it happen. Whether you're the performer on the stage, the dancer on the floor, the listener in the audience or the passenger being paged at the airport – QSC is passionate about the sound you hear.

This revised edition of the QSC catalog includes many QSC products that have proven their value, quality and reliability on the road and in permanent installations worldwide. And you will also see a number of new products that tightly integrate digital signal processing, power amplification and loudspeaker technologies into systems with performance that far exceeds the sum of their parts.

But there's more to it than the products, the systems and the science of it all. There's also the quality, service and commitment that QSC is known for. If you share our passion, we're sure that you'll enjoy learning about, installing and hearing our products as much as we enjoyed creating them.



# CONTENTS

<b>4</b>	<b>Amplifiers</b>	
	CMX Series	4
	GX Series	5
	RMX Series	6
	PLX2 Series	7
	PowerLight™ 3 Series	8
	CX Series	9
	ISA Series	10
	Amplifier Overview	12
	Amplifier Accessories	14

<b>18</b>	<b>Digital   Network</b>	
	Q-Sys™ Integrated System Platform	18
	Q-Sys™ Touch Screens	22
	Q-Sys™ Paging Stations	22
	QControl.net™ – BASIS™   RAVE   DSP	26
	NAC-100 Network Audio Controller	27
	SC28 System Controller	29

<b>32</b>	<b>Loudspeakers</b>	
	K Series Active Loudspeakers	32
	K Series Accessories	33
	KW Series Active Loudspeakers	34
	KW Series Accessories	35
	KLA Series Active Loudspeakers	36
	KLA Series Accessories	37
	ILA Series Installation Line Array	38
	WideLine-8 Line Array System	40
	WideLine-8 Subwoofers	42
	WideLine-10 Line Array System	44
	WideLine-10 Subwoofers	46
	Networked Concert System Solutions	48
	WLWX Weatherized WideLine™	49
	CSM Series Concert Stage Monitors	50
	AcousticDesign™ Ceiling Loudspeakers	52
	AcousticDesign™ Loudspeakers	56
	AcousticDesign™ Subwoofer	58
	ISIS Series Loudspeakers	60
	Understanding Sound Reinforcement	62

NAME: IOFrame8000 HOME  
DESIGN:  
STATUS: Idle

Q-SYS I/O FRAME





CMX 2RU Models

**NEW!** **CMX Series**

Installed Sound

The new CMX Series is our most economical and rugged power amplifier solution for any permanently installed sound system. It has input and output connections designed for the most flexible use in projects such as performance halls, houses of worship, sport clubs, gymnasiums, dance venues, pubs, and FGM/BGM systems. The CMX Series provides this unmatched performance and user ability at an affordable price point.

CMX Series	Watts per channel					
	70V	100V	Stereo		Bridged	
Model			8Ω	4Ω	2Ω*	4Ω*
CMX300V	-	-	200	300	430	830
CMX500V	-	-	280	500	700	1400
CMX800V	400	-	500	800	1200	2400
CMX2000V	2500	1000	1100	2000*	2500	5000

1 kHz, 0.1% THD  
\*1 kHz, 1% THD



CMX 3RU Model

- Flexible input connectivity choices including actively balanced; barrier strip, XLR, or 1/4" TRS.
- Flexible output connectivity choices include NL4 Speakon and Detachable Euroblock.
- Flexible output loading options that allow you to drive low impedance loads down to 2Ω and certain models to drive 70 and 100V distributed loudspeaker systems.
- Four models to choose from with power ranges from 300 watts to 2000 watts per channel.
- Rack mountable chassis less than 16" or 40.6 mm deep.
- Recessed front panel gain controls with 1 dB detents for fast and accurate level settings.
- Supplied Security plate cover for gain controls to provide tamper-proof protection.
- Recessed rear dip switches for easy selection between stereo, parallel, or bridged mode operation, and the additional choice of enabling/disabling low frequency filter protection.
- Balanced XLR and TRS parallel inputs accommodate the most commonly used input connectors for live sound and support loop-through routing.



## GX Series

GX5

Entertainers | Musicians | DJs

The GX Series amplifiers offer maximum performance, portability and reliability for sound system owners on a limited budget, perfectly suited for use by entertainers, musicians and DJs. The three GX Series amplifiers are uniquely designed to supply optimal power to the sound reinforcement loudspeakers most often used by entertainment professionals. The GX3 is ideal for speakers in the 300 watt (Program) range, while the GX5 provides full performance for 500 watt (Program) speakers. The new GX7 tops the range with power for 700 watt (program) speakers. All three models supply maximum possible power to 4Ω and 8Ω loads.

The use of subwoofers is supported with a crossover switch and front panel gain controls that allow easy access for balancing the sub with the full-range cabinet. GuardRail™ optimizes peak power to the two channels individually and its protection keeps the system working during demanding sets. With dramatic styling, easy hookup, flawless operation and protective circuitry, professional entertainers now have an amplifier that is designed for their specific application.

GX Series	Watts per channel	
Model	8Ω	4Ω
GX3	300	425
GX5	500	700
GX7	725	1000

Both channels driven.  
1 kHz, onset of clipping.



- Power levels matched to the most popular speakers used by entertainers.
- Optimized for maximum real-world headroom into 4Ω and 8Ω speaker systems.
- Inputs: XLR, 1/4" TRS and phono input connectors for compatibility with any source.
- Outputs: Speakon® combo accepts, 1/4" (TS) plugs or Speakon 2-pole and 4-pole plugs (connects 2 poles only). Binding posts support all other speaker wiring systems.
- Minimum depth chassis (10.1"/257 mm) fits in compact, inexpensive effects racks.
- Lightweight – GX3 and GX5 less than 26 lb (12.5 kg). GX7 only 15.5 lb (7 kg)\*
- Detented gain controls for precise setting and matching of sensitivity.
- GuardRail™ automatically protects the amplifier and loudspeakers from damage due to temperature rise or overdrive without shutting down the show.
- Front panel LEDs monitor Power, Signal and Clipping.
- Subwoofer/Satellite crossover built-in.

\*230V 16.5 lb (7.5kg)



RMX 2RU Models

## RMX Series

Entertainers | Musicians | DJs  
Concert Systems

The RMX Series is a proven line of amplifiers combining legendary QSC reliability, audio performance and affordability. Entertainers and touring users have made RMX one of the leading amplifier series in the world. For mid-power applications, the 2RU models offer 4Ω power ratings from 300 to 750 watts per channel. For premium loudspeaker systems with extremely high power capacity the 3RU models (RMX4050HD and RMX5050) are unchallenged.

- Independent, defeatable clip limiters reduce distortion and protect speakers.
- Selectable low-frequency filters (30 or 50 Hz) protect speakers and increase headroom.
- Flexible output loading options that allow you to drive low impedance loads down to 2Ω.
- Six models to choose from with power ranges from 300 watts to 2000 watts per channel at 4Ω.
- Rack mountable chassis less than 16" or 40.6 mm deep.
- Recessed front panel gain controls with 1 dB detents for fast and accurate level settings.



RMX 3RU Models

RMX Series	Watts per channel			
	Stereo		Bridged	
Model	8Ω	4Ω	2Ω*	4Ω*
RMX850	200	300	430	830
RMX1450	280	450	700	1400
RMX1850HD	360	600	900	1800
RMX2450	500	750	1200	2400
RMX4050HD	850	1400	2000	4000
RMX5050	1100	1800	2500	5000

1 kHz, 0.1% THD \*1 kHz, 1% THD

RoHS





PLX2 "02" Models

## PLX2 Series

Entertainers | Musicians | DJs  
Concert Systems

The PLX2 Series are powerful, lightweight amplifiers designed to meet the rigorous demands of live musicians, mobile entertainers, and portable PAs. Featuring third generation **PowerLight™** technology, the PLX2 Series delivers superb overall audio quality with especially powerful low-frequency performance. The PLX2 Series amps have a professional, attractive appearance, with a die-cast aluminum front panel acting as an integral I-beam, to create an extremely rugged, road-worthy device.

PLX2 consists of two series. The "02" models (1802, 2502, 3102, 3602) can drive 2Ω loads and include subwoofer filtering and other signal processing amenities. For applications that do not require bridging, 2Ω operation, or internal subwoofer signal processing, the "04" models (1104, 1804) deliver the same audio performance as the "02" models in a lighter-weight, more cost-effective unit.

- Front panel LED status indicators enable system monitoring and troubleshooting.
- Front panel gain controls (1 dB detents) allow precise input sensitivity adjustment.
- Speakon® NL-4 output connectors provide a positive-locking speaker connection. Channel 1's output can use all four wires to connect to bi-amplified speakers with a single cable.
- Balanced XLR and TRS parallel inputs accommodate the most commonly used input connectors for live sound and support loop-through routing.
- *Active Inrush Limiting* prevents AC mains circuit breakers from popping during turn-on.



The "04" models (PLX1104 and PLX1804) offer advanced PLX2 technology with less weight, less chassis depth and even greater value for users who don't require 2Ω or bridged operation.



PLX2 "04" Models

PLX2 Series	Watts per channel			
	Stereo		Bridged	
Model	8Ω*	4Ω*	2Ω**	4Ω**
PLX1104	325	550	—	—
PLX1804	600	900	—	—
PLX1802	330	575	900	1800
PLX2502	450	750	1250	2500
PLX3102	600	1000	1550	3100
PLX3602	775	1250	1800	3600

\*1 kHz, 0.1% THD, both channels driven

\*\*1 kHz, 1% THD, both channels driven



# PowerLight™ 3 Series

Concert Systems  
Installed Sound

The PowerLight 3 Series are Pat Quilter's "Ultimate Analog" amplifiers, designed for the most demanding concert and live-sound reinforcement applications. All three models use our latest generation **PowerLight™** technology – the world's most efficient power supply. The 8000 watt Class D PL380 shares a clean, efficient control, connector and indicator layout with the Class H PL340 (4000 watts) and PL325 (2500 watts). All PowerLight 3 Series amplifiers have zero signal latency, for seamless integration with existing equipment and flawless loudspeaker alignment. The flexible PowerLight 3 Series architecture provides users the choice of comprehensive, networked remote control, monitoring and DSP or the cost savings of a simple, straightforward analog input configuration.

## The PL380 amplifier now includes a detachable power cord featuring 32 amp PowerCON® connectors from Neutrik.™

PowerCON connectors are a robust and reliable AC cable connector with high current capacity (32 amps) designed expressly to meet the needs of high-power distribution systems. An inherent part of the PowerCON design, the connector facilitates fast and easy locking, protecting against unintentional disconnects.

PL380 plug types remain unchanged, with the existing NEMA L5-30P plug found on all 120V and 100V PowerLight PL380 amplifiers, and a "Shuko" CEE 7/7 16 amp Continental European plug still in place on the 230V PL380. All PowerLight PL325 and PL340 amplifiers will retain their existing 20 amp PowerCon connectors and plug types.



Integration of QSC DataPort-equipped amplifiers is elegantly simple. Amplifier parameters may be monitored and controlled in real-time over the network using the Q-Sys™ user interface.

\*PowerCON and Neutrik are trademarks of Neutrik.



PL380



PL325 and PL340



To prevent unauthorized adjustment of input attenuation settings, a security lockout plate is included with every PowerLight 3 amplifier.



PL380 output device (left) compared with typical output devices.

- New 32 A PowerCON on PL380
- A three-position Input Sensitivity switch makes it easy to integrate PowerLight 3 Series amplifiers into existing amp racks and power systems.
- Zero signal latency processing is standard on all PowerLight 3 amplifiers, with either the DSP-4 rear panel module, Q-Sys™ or QControl.net™ BASIS™ units. SC28 or other loudspeaker management processors can also be used.
- XLR, Euroblock and DataPort connectors simplify signal connections, allowing multiple options for loop-through wiring.
- Comprehensive internal protection is designed to protect amplifiers and speakers against over-current, excessive AC voltage, over-temperature and clipping – all without compromising the integrity of normal program signals.

PL3 Series	Watts per channel		
Model	8 Ω	4 Ω	2 Ω
PL325	500	850	1250
PL340	800	1250	2000
PL380	1500	2500	4000*

EIA 1 kHz, 1% THD

\*Burst mode testing required due to AC

service current limitations





## CX Series

### Installed Sound

The CX Series is a range of two, four and eight channel amplifiers designed for installations requiring premium sound quality and high output power. The CX Series has the added capability for advanced amplifier control and monitoring via Q-Sys and QSCControl.net series of products. Recognized by sound contractors worldwide as the standard for reliability, the 2RU CX Series features **PowerLight™** power supply technology which reduces weight while also improving audio quality and eliminating AC mains hum. The PowerLight supply also results in very high efficiency so CX amplifiers draw less power and produce less heat for savings on energy and air conditioning.

- *Active Inrush Limiting* brings the amplifiers on line gently, eliminating the need for costly AC power sequencers.
- Front-panel gain controls with 1 dB detents allow precise level adjustment and are protected by tamper-proof security covers.
- DataPort connects directly to QSC accessories and digital signal processors for extensive remote control and monitoring of amplifier functions via Q-Sys™ and QSCControl.net.™
- Selectable clip limiters and infra-sonic filters protect loudspeakers from damage due to distortion and overexcursion.
- Transformerless 70 volt and low-impedance models are available.
- Connectors: Input – XLR/F and 3-pin Euroblock. Output – barrier strip.
- Sleep (Standby) Mode capable for energy saving efficiency.



CX 2-channel Models



CX 4-channel Models



CX 8-channel Models

CX Series	Watts per channel			
<b>2-Ch Models</b>	70 V*	8 Ω	4 Ω	2 Ω**
CX302V	250	–	–	–
CX602V	440	550	–	–
CX1202V	1000	700	1100	–
CX302	–	200	325	600
CX502	–	300	500	800
CX702	–	425	700	1200
CX902	440	550	900	1500
CX1102	1000	700	1100	1700
<b>4-Ch Models</b>	70 V*	8 Ω	4 Ω	2 Ω**
CX204V	220	–	–	–
CX254	–	170	250	450
CX404	–	250	400†	–
<b>8-Ch Models</b>	70 V††	8 Ω	4 Ω§	
CX108V	100	–	–	
CX168	–	90	130	

All channels driven.  
 20 Hz – 20 kHz, 0.05% THD  
 \*1 kHz, 0.05% THD  
 \*\*1 kHz, 1% THD  
 †1 kHz, 0.1% THD  
 ††20 Hz – 20 kHz, 0.2% THD  
 §20 Hz – 20 kHz, 0.1% THD

**RoHS**



## ISA Series

### Installed Sound

The ISA amplifiers are ideal for fixed installations when multi-way loudspeaker systems are required. Taking advantage of the DataPort V2 Lite connection, you can attach our amplifier accessories to provide an economical solution for crossover and subwoofer filtering without the expense of a separate DSP device. The ISA Series also provides “Ti” models, which incorporates output isolation transformers for 70/100-Volt distributed loudspeakers requiring them. The 3RU ISA Series offers models capable of driving 2-ohm loads and models with selectable 25, 70, and 100 volt distributed systems.

- Rear-mounted gain controls with 2 dB detents provide repeatable settings.
- Independent, defeatable clip limiters reduce distortion and protect speakers.
- Selectable high-pass filters protect against transformer saturation and driver overexcursion.
- Includes extensive DC, infrasonic, thermal overload, and short circuit protection.

- DataPort V2 is included for connection of DPV2-compatible signal processing accessories. (XC-3, LF-3 and SF-3.)
- Connectors: Input – XLR/F and 3-pin Euroblock. Output – barrier strip.
- The “Ti” versions have the capability to power one output channel at low impedance (8, 4, or 2-ohm) while the other can power high impedance (25, 70, 100V).
- The DataPort connector on this amplifier is **not compatible** with Q-Sys, BASIS or CM16a

ISA Series	Watts per channel			
	70V/100V	8Ω**	4Ω**	2Ω†
ISA280	—	185	280	430
<b>THX</b> ISA450	—	260	425	700
<b>THX</b> ISA750	—	450	650	1200
ISA1350	1500††	800	1300	2000
ISA300Ti	300	185	280	430
ISA500Ti	500	260	425	700
ISA800Ti	800	450	650	1200

\*50 Hz – 16 kHz, 0.5% THD

\*\*20 Hz – 20 kHz, 0.1% THD

†1 kHz, 1% THD

††Direct Output, 70V, less than 0.1%

THD, 20 Hz – 20 kHz, +0/-0.3 dB

**RoHS**



# Amplifier Overview

AMPLIFIERS

CMX SERIES	Channels	Watts per channel						RU	Net Weight / Shipping
		70 V	100V	8Ω	4Ω	2Ω	Bridged		
CMX300V	2	–	–	200	300	430	830	2	35 lb (15.9 kg) / 41 lb (18.6 kg)
CMX500V	2	–	–	300	500	700	1400	2	40 lb (18.2 kg) / 46 lb (20.9 kg)
CMX800V	2	400 W	–	500	800	1200	2400	2	44.5 lb (20.2 kg) / 50.5 lb (23 kg)
CMX2000V	2	2500 W	1000 W	1100	2000	2500	5000	2	75 lb (33.1 kg) / 87 lb (37.2 kg)
<b>GX SERIES</b>									
GX3	2	–	–	300	425	–	–	2	27 lb (12.1 kg) / 31 lb (14.1 kg)
GX5	2	–	–	500	700	–	–	2	28 lb (12.6 kg) / 32 lb (14.6 kg)
GX7	2	–	–	725	1000	–	–	2	17 lb (7.7 kg) / 21 lb (19.5 kg)
<b>RMX SERIES</b>									
RMX850	2	–	–	200	300	430	830	2	35 lb (15.9 kg) / 41 lb (18.6 kg)
RMX1450	2	–	–	280	450	700	1400	2	40 lb (18.2 kg) / 46 lb (20.9 kg)
RMX1850HD	2	–	–	360	600	900	1800	2	44.5 lb (20.2 kg) / 50.5 lb (23 kg)
RMX2450	2	–	–	500	750	1200	2400	2	44.5 lb (20.2 kg) / 50.5 lb (23 kg)
RMX4050HD	2	–	–	850	1400	2000	4000	3	68 lb (30.8 kg) / 77 lb (34.9 kg)
RMX5050	2	–	–	1100	1800	2500	5000	3	75 lb (33.1 kg) / 87 lb (37.2 kg)
<b>PLX2 SERIES</b>									
PLX1104	2	–	–	325	550	–	–	2	13 lb (5.9 kg) / 18 lb (8.2 kg)
PLX1804	2	–	–	600	900	–	–	2	13 lb (5.9 kg) / 18 lb (8.2 kg)
PLX1802	2	–	–	330	575	900	1800	2	21 lb (9.5 kg) / 26 lb (11.8 kg)
PLX2502	2	–	–	450	750	1250	2500	2	21 lb (9.5 kg) / 26 lb (11.8 kg)
PLX3102	2	–	–	600	1000	1550	3100	2	21 lb (9.5 kg) / 26 lb (11.8 kg)
PLX3602	2	–	–	775	1250	1800	3600	2	21 lb (9.5 kg) / 26 lb (11.8 kg)



PL3 SERIES	Channels	70 V	Watts per channel				Bridged	RU	Net Weight / Shipping
			8Ω	4Ω	2Ω				
PL325	2	–	500	850	1250	2500	2	22 lb (10 kg) / 31.5 lb (14.3 kg)	
PL340	2	–	800	1250	2000	4000	2	22 lb (10 kg) / 31.5 lb (14.3 kg)	
PL380	2	–	1500	2500	4000	8000	2	24 lb (11 kg) / 33.5 lb (15.2 kg)	
<b>CX SERIES</b>									
CX302	2	–	200	325	600	1200	2	21 lb (9.5 kg) / 27 lb (12.3 kg)	
CX502	2	–	300	500	800	1600	2	21 lb (9.5 kg) / 27 lb (12.3 kg)	
CX702	2	–	425	700	1200	2400	2	21 lb (9.5 kg) / 27 lb (12.3 kg)	
CX902	2	440	550	900	1500	3000	2	21 lb (9.5 kg) / 27 lb (12.3 kg)	
CX1102	2	1000	700	1100	1700	3400	2	21 lb (9.5 kg) / 27 lb (12.3 kg)	
CX302V	2	250	–	–	–	–	2	21 lb (9.5 kg) / 27 lb (12.3 kg)	
CX602V	2	440	550	–	–	–	2	21 lb (9.5 kg) / 27 lb (12.3 kg)	
CX1202V	2	1000	700	1100	–	–	2	21 lb (9.5 kg) / 27 lb (12.3 kg)	
CX254	4	–	170	250	450	900	2	21 lb (9.5 kg) / 27 lb (12.3 kg)	
CX404	4	–	250	400	–	–	2	21 lb (9.5 kg) / 27 lb (12.3 kg)	
CX204V	4	200	–	–	–	–	2	21 lb (9.5 kg) / 27 lb (12.3 kg)	
CX168	8	–	90	130	–	–	2	21 lb (9.5 kg) / 27 lb (12.3 kg)	
CX108V	8	100	–	–	–	–	2	21 lb (9.5 kg) / 27 lb (12.3 kg)	
<b>ISA SERIES</b>									
		<b>70V/100V</b>							
ISA280	2	–	185	280	430	830	3	36 lb (16.3 kg) / 42 lb (19.1 kg)	
ISA450	2	–	260	425	700	1400	3	42 lb (19 kg) / 48 lb (22.0 kg)	
ISA750	2	–	450	650	1200	2400	3	47 lb (21.3 kg) / 53 lb (24.0 kg)	
ISA1350	2	–	800	1300	2000	4000	3	68 lb (30.8 kg) / 77 lb (34.4 kg)	
ISA300Ti	2	300	185	280	430	830	3	44 lb (20.0 kg) / 50 lb (22.7 kg)	
ISA500Ti	2	500	260	425	700	1400	3	49 lb (22.3 kg) / 55 lb (25 kg)	
ISA800Ti	2	800	450	650	1200	2400	3	57 lb (26 kg) / 63 lb (28.6 kg)	

## Amplifier Accessories



DSP-30

### DSP-3 | DSP-4 | DSP-30

The DSP-3 and DSP-4 are compact, 2-channel signal processing modules that can plug into the back of most DataPort-equipped QSC amps to conserve rack space and simplify interconnection. They can also be mounted into a DPX-4 remote rack mounting bracket for use as a standalone, rack-mounted processing unit. The DSP-3/4 are professional audio processors featuring 24-bit/48 kHz A/D converters, balanced inputs, and presets that can be selected without turn-on pops or zipper noise. Their processing power is dynamically allocated, removing the limitations imposed by fixed signal-chain designs. The power and flexibility of the DSP-3/4 eliminates expensive outboard DSP gear, which reduces cost and installation time and simplifies setup.

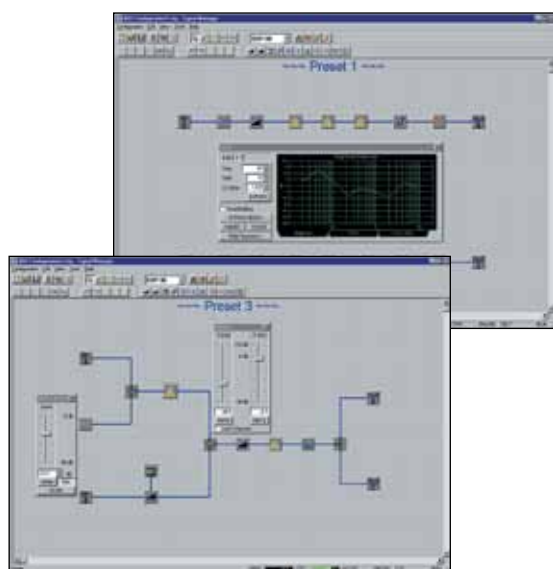

The DSP is configured with an easy-to-use software interface. Signal processing icons from the toolbar are dropped onto the workspace and the signal path is routed with simple drawing tools.

The DSP-30 is a rack-mount device almost identical to the DSP-3. The other main differences between these three devices are their dynamic range specifications and output connectors.

Our PC-based Signal Manager software uses simple drag-and-drop tools to:

- Configure the processing functions and signal flow.
- Display a graphical representation of DSP resources.
- Produce hardcopy printout of signal flow and/or parameter settings.
- Perform firmware upgrades via RS-232.

Each channel includes:

- Crossover filters: Bessel, Butterworth, Linkwitz-Riley.
- Compressors and limiters.
- Multiple parametric EQs.
- Precision attenuation (0.1 dB steps).
- High and low-shelf filters.
- Mix post-crossover audio (2-to-1 mixer).
- Multiple delays (max. 910 ms).
- Variable-frequency tone generator.
- Pink and white noise generators.
- Signal mute, splitter, and polarity reversal.

Model	Dynamic Range (unweighted)	Output Connectors
<b>DSP-3</b>	>93 dB, 20 Hz to 20 kHz 1.5, 4, 9 V sensitivities	3-pin Euroblock
<b>DSP-4</b>	>104 dB 20 Hz to 20 kHz, 1.5, 4, 9 V sensitivities	XLR
<b>DSP-30</b>	>95 dB 20 Hz to 20 kHz, 1.5, 4 and 9 V sensitivities	XLR

RoHS



### XC-3 2-way Crossover

The XC-3 is an active, 2-way crossover module that mounts to the rear panel DataPort of 2-channel QSC amps (DCA, PL2, PL3, CX, ISA).



The XC-3 features 4th order Linkwitz-Riley filters (24 dB/octave) with the low frequencies routed to amp channel 1 and the highs to channel 2. Each channel has an all-pass filter delay for time alignment of low- and high-frequency drivers, and a trim control (0-20 dB attenuation) to balance the frequency bands. The high-frequency channel offers up to 10 dB of boost at 20 kHz to properly equalize constant-directivity horns. A 3-way crossover can be implemented using the XC-3's low-frequency high-pass filter with the LF-3.

### SF-3 Subwoofer Filter

The SF-3 subwoofer filter provides subwoofer signal processing without the need for a conventional crossover. The unit mounts to the rear panel DataPort of 2-channel QSC amps (DCA, PL2, PL3, CX, ISA) to conserve cost and rack space. A 4th order Linkwitz-Riley low-pass filter may be set to 80, 150 or 250 Hz. The subsonic filter offers roll-off frequencies in the range 20-50 Hz to prevent driver overexcursion. An optional EQ is provided to extend the response of B6 speaker enclosures. A trim control (0-20 dB of attenuation) allows balancing the various frequency bands.



#### DataPort

The QSC DataPort provides a simple, convenient means of connecting and powering digital and analog accessory devices to expand the capabilities of QSC CX, DCA, PowerLight™, PowerLight 2 and PowerLight 3 amplifiers. Devices supported include the DSP-3, DSP-4, XC-3, LF-3 and SF-3. Note that ISA models require an external power adapter for the DSP devices, and PL380 for the DSP-3 device.

In addition, the DataPort HD15 connector provides a single-cable interface to Q-Sys™ and QSCControl.net™. Q-Sys and QSCControl.net allow remote amplifier monitoring and control. This functionality is supported by CX, DCA, PowerLight, PowerLight 2 and PowerLight 3 amplifiers.

Please see the specifications for the specific accessory devices and amplifiers before planning a system.

### LF-3 Low-Frequency Filter

The LF-3 low-frequency filter, when used with the XC-3 2-way crossover, provides a 3-way active crossover system.

The LF-3 mounts to the rear panel of 2-channel QSC amps (DCA, PL2, PL3, CX, ISA) to conserve cost and rack space. The LF-3 is comprised of two discrete channels with 4th order Linkwitz-Riley low-pass filters (24 dB/octave slope). Each channel has a delay to time-align low-, mid-, and high-frequency speakers, and a trim control (0-20 dB of attenuation) to match levels. One amp-mounted LF-3 supports up to two other amps (even in stereo) with XC-3 accessories installed.



### OT-300a Output Autoformer

The OT-300a is a robust step-up autoformer accessory that adapts power amplifier outputs (maximum voltage range 17-35 volts) to drive a 70 volt distributed line with up to 300 watts. Four voltage taps can be selected to match the output voltage of your amplifier. Conversely, the OT-300a can be used as a high-power speaker transformer, driving speakers with up to 300 watts from a 70 volt distributed line. The OT-300a is compatible with any amplifier rated at up to 350 watts at 4Ω.

### OT-600 Output Autoformer

The OT-600 is a robust step-up autoformer accessory that adapts power amplifier outputs (maximum voltage range 40-50 volts) to drive a 70 volt distributed line with up to 600 watts. Three voltage taps can be selected to match the output voltage of your amp. The OT-600 can also drive a 100 volt line when used with an amp with a maximum output voltage in the range 55-70 volts. Conversely, the OT-600 can be used as a high-power speaker transformer, driving speakers with up to 600 watts from a 70 volt distributed line. The OT-600 is compatible with amps rated between 350 and 650 watts at 4Ω.

### IT-42 Output Isolation Transformer

The IT-42 is an output isolation transformer accessory for the QSC CX302 amplifier, allowing it to drive two 25, 70 and 100 volt distributed lines in stereo or parallel or a single 140 or 200 volt line in bridged mono. The IT-42 is pre wired for quick and convenient mounting to the back of the CX302 amplifier and requires no additional rack space.

All the accessories listed are RoHS compliant. **RoHS**





# Rethink everything... We did.



## Q-SYS™

Q-Sys™ is a complete, integrated platform for audio system routing, control, processing, monitoring, and configuration. Built on state-of-the-art technology, Q-Sys is optimized for the rigorous demands of large-scale applications, efficiently and reliably addressing every aspect of a facility's audio needs. From inputs to loudspeakers, Q-Sys maintains the top-notch sound quality for which QSC is renowned while providing user-friendly management of complex audio requirements. Wherever audio systems are installed, Q-Sys is the ideal solution for powerful system-wide control.

### Components

The primary elements of a Q-Sys system are the Core, the I/O Frame, Q-Sys Designer software, and the Q-LAN network. The Core is the brain of the system; performing all audio routing, processing, and control functions. I/O Frames provide the interfacing capability that gets audio and other data into and out of the system. Q-Sys Designer provides the interface for system design, configuration, and control. And Q-LAN connects the system into an integrated whole. Additional application-specific functionality may be added with

optional hardware components such as the Q-Sys Page Station and the TSC-8 Touch Screen Controller.

### Q-Sys™ Core

With a centralized processing architecture based on mainstream server and workstation technology, the Q-Sys Core has several distinct advantages over competing systems. Because the Core isn't locked into a narrow, proprietary platform, Q-Sys hardware and software will always be able to keep pace with the latest developments in the overall IT industry. And our centralized approach to



I/O Frames



Core

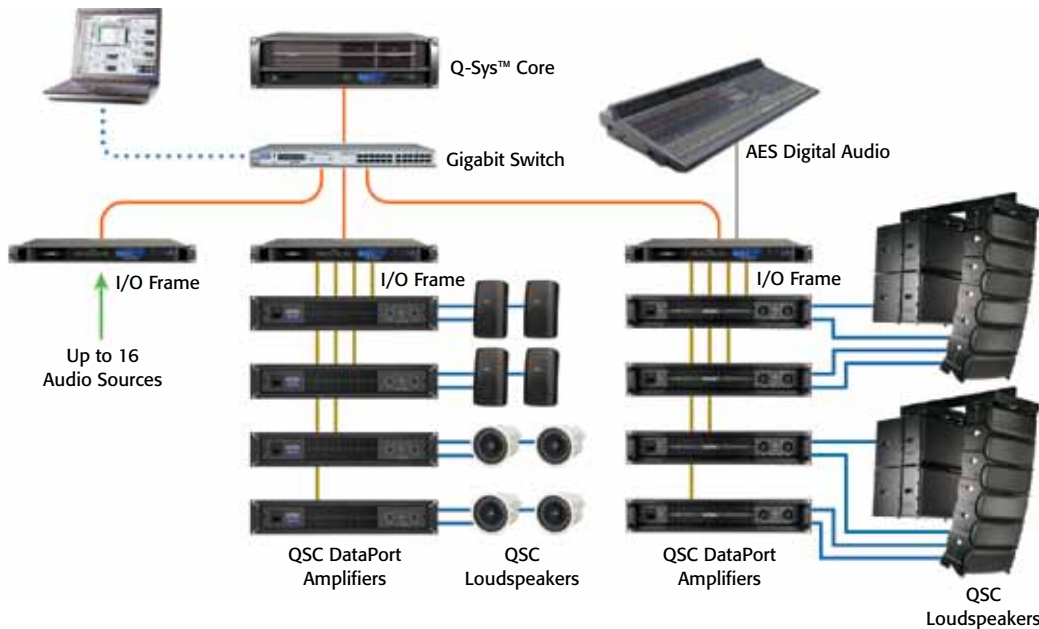

DIGITAL | NETWORK

processing allows the system's full power to be flexibly allocated as needed, without the capacity chokepoints inherent in distributed processing. That vastly simplifies the job of audio system design, allowing any input to be routed to any output without convoluted, variable-latency signal paths. And it also keeps system redundancy very straightforward.

Centralized architecture also enables more efficient networking. Because the Core handles all control and monitoring, fewer control connections are needed for remote devices. Less traffic takes up less bandwidth, leaving greater overall system capacity.

The Q-Sys Core is available in three sizes tailored to the varying requirements of different facilities: Core 1000, Core 3000, and Core 4000.

	Maximum Input Channels	Maximum Output Channels
Core 1000	64	64
Core 3000	128	128
Core 4000	128-512*	128-512*

\* Up to 512 network audio channels when an average of 8 or more channels per network audio stream are used.

### I/O Frame

Physically located near audio sources and destinations, I/O Frames provide the points of connection used to interface Q-Sys with other components of the audio system, such as mixers and power amplifiers. Each I/O Frame enables up to 16 channels of input and/or output by housing up to four of the following I/O cards, which may be mixed and matched in a single unit:

- **Mic/Line Input card** – Four channels of switchable mic/line-level analog audio input with 48V phantom power (available with standard or premium pre-amps and A/D converters).
- **Line Output card** – Four channels of balanced, line-level analog output.
- **DataPort Output card** – Four audio output channels (2 DataPorts) for connection to DataPort equipped QSC amplifiers.
- **AES Input/Output card** – Four input and four output channels of AES-3 digital audio.
- **CobraNet Input/Output card** – Up to 32 input and 32 output channels available when used in a core, 16 x 16 in an I/O Frame.

Additional cards are under development; check the QSC website for the latest information.

Q-Sys™ employs a 64-bit processing engine, low latency 32-bit floating point distribution, and high performance A/D and D/A converters to provide audiophile quality.

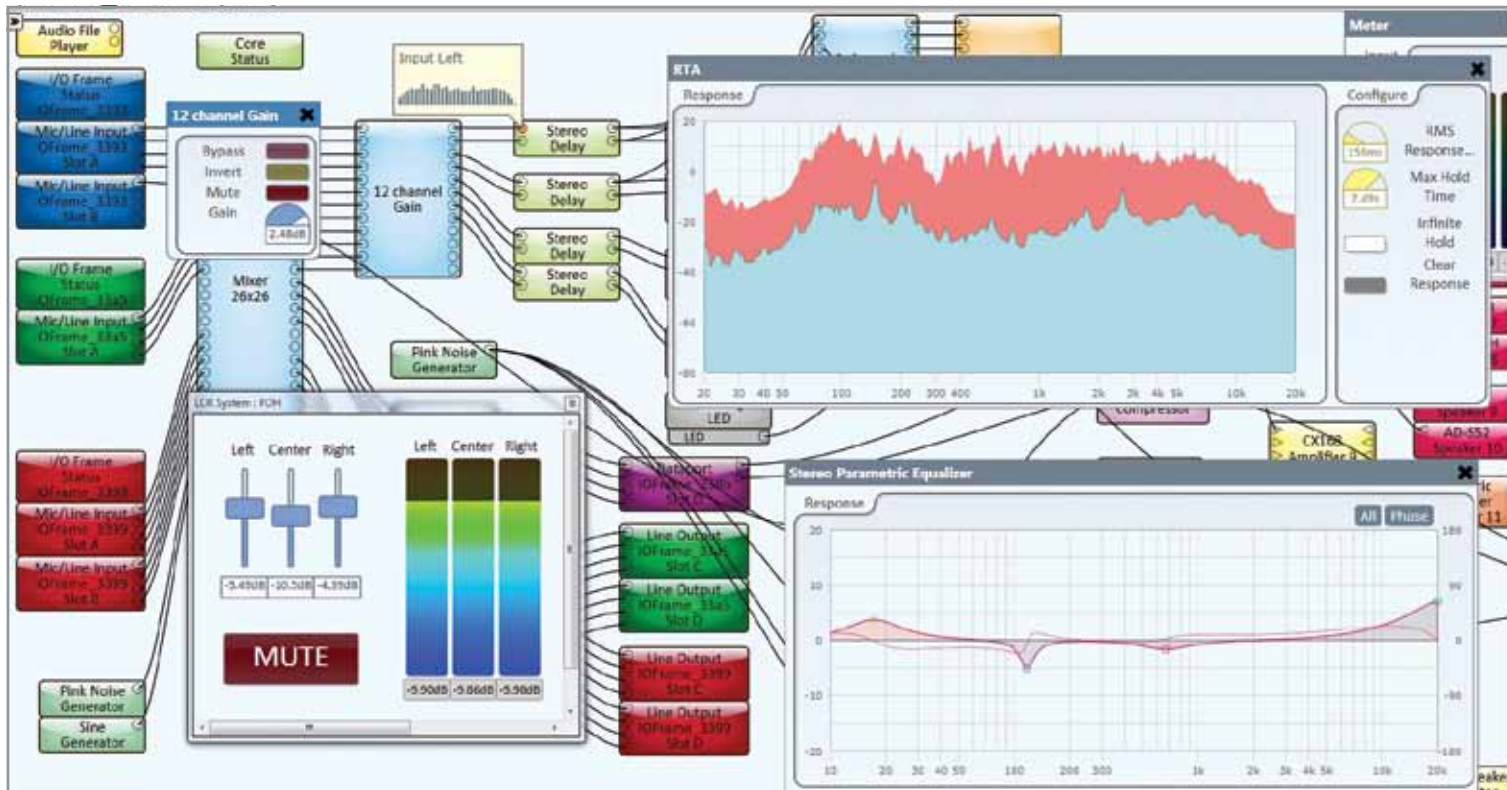

Screenshot: All system elements are brought under one intuitive GUI in Q-Sys™ Designer.

## Q-Sys™ Designer Software

Your audio system may be complex, but designing and controlling it should be simple. That's why we made the Q-Sys Designer environment so intuitive and easy to use, giving you powerful tools without clutter or complication. Drop in components from easy-to-access inventories, click to set properties, and drag to connect. As you build your design graphically in the Schematic window, Q-Sys automatically handles all the network configuration details behind the scenes. Within minutes, you'll be able to create not only a clear overall picture of your system but a fully-operational configuration that's ready to use on the Q-Sys Core.

With Q-Sys Designer's Design and Emulate modes, you can work on system designs

even when you're not connected to a Q-Sys Core. As you work, the Design Inspector automatically checks your current configuration, looking for orphaned controls or unterminated signals that could cause potential issues. Once your Q-Sys Designer configuration is complete you can connect to a Core — locally or via the Internet — and deploy the design in Run mode.

Unlike many competing systems, designs are compiled and ready to run in just seconds. With no barrier to trying different options, you can rapidly refine your designs for the best results while still saving time during system set-up and commissioning. And with Designer's User Control Interface tools, you'll also be able to quickly create custom interfaces allowing any or all aspects of the system to be operated from any PC on the network.

While Q-Sys Designer's interface is straightforward, the system's capabilities are deep and powerful. A complete range of DSP processing covers not only standards like EQ, dynamics, and delays, but also a library of ready-made loudspeaker-specific optimizations. You can mix and route any signal, insert meters anywhere, and monitor amplifier performance. You can measure and troubleshoot using built-in tools such as a test probe that provides an RTA display of the signal. And with a measurement microphone you can even perform on-site acoustical measurements using FFT-based real-time analysis and impulse response tools. In short, Q-Sys Designer provides everything you need to configure, operate, and maintain your audio system at the highest level of performance.

## Q-Sys™ Capabilities

More than just the sum of its parts, Q-Sys is a complete solution that brings together all the capabilities needed to enable unprecedented control of your audio system. Our DSP engine gives you unrivalled processing breadth and depth. Flexible and powerful controllers give you a multitude of ways to tailor the system to your specific needs. Redundancy-friendly design makes it easy to protect critical functions against downtime. And built-in integration with QSC amplifiers and loudspeakers lets you control and monitor every aspect of system performance.

## Q-Sys™ Processing

Q-Sys is designed from the ground up to bring nearly unlimited DSP resources to bear for processing. Even in the smallest Core (Core 1000), 64-bit internal processing ensures high performance and incredible headroom. Most processing functions are capable of providing up to 256 channels simultaneously, and mixers can provide up to 512 input and output channels. This DSP power can be applied across a huge array of functions covering every aspect of enhancement, monitoring, testing, and control.

### Crossovers

- Up to 6-way
- Butterworth, Linkwitz-Riley, Bessel-Thompson, and Chebyshev Topologies

### Delay

- Up to 512 taps of up to 60 sec. each

### Dynamics

- Ambient Noise Compensator
- Automatic Gain Control
- Compressor
- Expander
- Noise Gate
- Peak Limiter
- Priority Ducker

### Meters

- RMS/Peak Bar Meter
- Signal Presence Meter

### Filters & Equalizers

- All-Pass Filter
- Band-Pass Filter
- High-Pass Filter
- Low-Pass Filter
- Notch Filter
- Dual-Shelf Equalizer
- Graphic Equalizer
- High-Shelf Equalizer
- Low-Shelf Equalizer
- Parametric Equalizer
- FIR Custom Filter
- FIR High-Pass Filter
- FIR Low-Pass Filter

### Mixers & Routers

- Gain-Sharing Automatic Mixer
- Gated Automatic Mixer
- Matrix Mixer
- Room Combining Mixer
- Router
- Delay Matrix

### Test & Measurement

- DC Generator
- Pink Noise Generator
- White Noise Generator
- Sine Wave Generator
- Signal Injector (insert signal anywhere in the audio path)
- Signal Probe (insert probe anywhere in the audio path)
- Real Time Analyzer
- Responsalyzer 2-channel FFT measurement (Magnitude, Phase, Impulse Response, and Real Time Analysis)

### Other

- Amplifier Load Monitoring
- Audio File Player for .wav and .mp3 files (direct from Core)
- Loudspeaker Supervision
- Emergency System Mute



Peak Limiter



24 x 8 Mixer

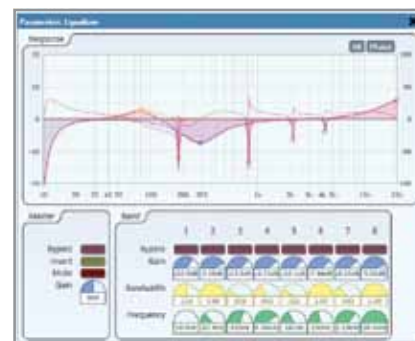

Parametric Equalizer

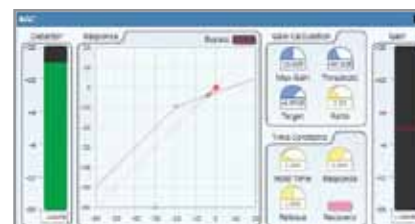

Auto Gain Control

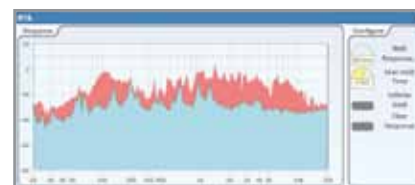

Real Time Analyzer

**NEW!**

### TSC-8 Touch Screen Controller

Whether you're recalling a few simple snapshots or using faders, knobs, and buttons to manipulate multiple parameters, touch screens provide an ideal user interface for system control. With capacitive touch technology and a bright 800 x 600 full-color LCD, the dual-port TSC-8 makes the perfect networked controller, not only for Q-Sys parameters and functions but also for managing a wide variety of equipment via the Q-Sys Core's General Purpose I/O (GPIO) and TCP/IP instruction sets. Multiple TSC-8s, each using a different interface created in Q-Sys Designer, may be attached to the network simultaneously, with each unit's display updated automatically as changes are made with other units.



### Q-LAN

Q-LAN is a blazing-fast Gigabit Ethernet implementation that delivers audio from any end-node to the Q-Sys Core in less than 1/3 millisecond. Q-LAN's speed and capacity allow Q-Sys to deliver overall system latency – including core processing and both A/D and D/A conversions – of less than 2.5 milliseconds from any input to any output with up to seven network switch hops.

In addition to low-latency distribution, Q-LAN supports much higher channel capacity than competing systems (– up to 512 bidirectional channels –) and greatly simplifies implementation of full system redundancy. Q-Sys also supports long-haul IP streaming of audio over Wide Area Networks (WAN) as well as auto-discovery and configuration of end nodes.

Since specialty semi-conductors and non-standard hardware can lead to dependence on obsolete technologies, Q-LAN is based instead on standards and protocols from the IT industry, where a huge market guarantees ongoing support and development. Q-LAN uses widely available off-the-shelf Gigabit switches. And Q-LAN's use of Layer 3 (TCP/IP) protocol allows transmission of Q-Sys audio with other IT traffic, eliminating the need for facilities to run a dedicated audio network. The result is a system that takes maximum advantage of the capabilities of standards-based IP networking, achieving outstanding performance while maximizing network compatibility.

While Q-LAN is the ideal network for a fully-integrated Q-Sys environment, QSC also offers a CobraNet card for interfacing with legacy systems. At the same time, the Q-Sys architecture is designed to allow future compatibility with alternative protocols such as AVB if and when they achieve widespread adoption.



### Q-Sys™ Page Station

**NEW!**

Enabling live paging to selected zones, the Q-Sys Page Station extends Q-Sys functionality in transportation, hospitality, medical, and other similar applications. Available with either gooseneck or handheld microphone (push to talk), Q-Sys Page Station is a dual-port network device that is fully configurable from Q-Sys Designer. A front panel user interface includes a capacitive touchpad that offers visible feedback and audible cues. Paging status, alerts, and operational details are also reported via illuminated status indicators and a built-in LCD display.





## Q-Sys™ Control

In addition to powerful processing, Q-Sys offers extensive system control capabilities that can be as simple or sophisticated as the application requires. Nearly every audio processing parameter can be a command source or destination, as can switch closures or potentiometers via on-board GPIO. Control-specific operators like Boolean Logic or Arithmetic functions can be applied to enhance management capabilities based on operator or system control input. And snapshots of any or all functions can be created and recalled using the Snapshot tool.

Q-Sys also includes several additional tools addressing specific aspects of system control:

- **User Control Interface tool** — Q-Sys Designer’s UCI tool lets you create custom control panels that may be viewed and operated by an end-user from any computer on the network, or Wi-Fi connected iPad or iPhone. Allowing a unique look and feel, these controls may be built from scratch using the provided templates or by pulling in elements directly from the system schematic.



Custom control panel served on an iPhone.

- **Administration Interface** — Designed for configuration and maintenance of a deployed Q-Sys system, the powerful Administration Interface covers areas such as setting priority modes and levels, creating and scheduling commands, defining access levels for different users, managing PA zones, scheduling playback of core-hosted audio files, and logging of events. Every aspect of efficient system-wide operation has been considered and addressed.

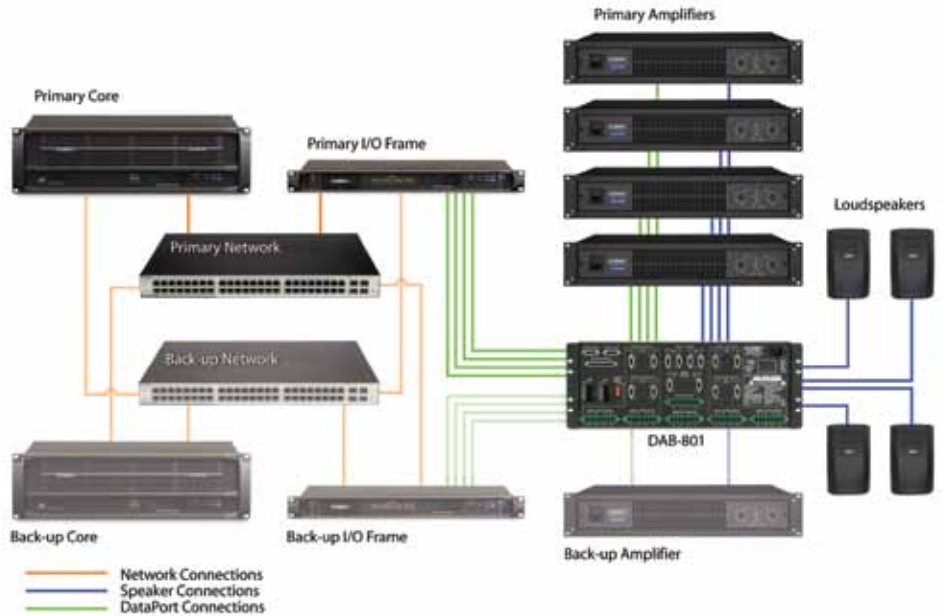

## Q-Sys™ Redundancy

While QSC products are renowned for their reliability, redundancy is the best insurance against failure for mission-critical components. Q-Sys facilitates multiple levels of redundancy.

- **Network redundancy** may be implemented by simply adding additional network switches and cabling. In the event of a network failure, the Q-Sys components switch over instantly to the back-up network.
- **Core redundancy** allows a second Core to be connected to the network. Should

the primary Core fail, the secondary Core takes over.

- **I/O Frame redundancy** gives the designer the option of adding redundant I/O Frames for high-priority areas.
- **Amplifier redundancy** is made possible with the QSC DAB-801 (DataPort Amplifier Backup panel), which configures five 2-channel QSC DataPort amplifiers so that the fifth amp automatically kicks in if a problem is detected with any of the other four (4 + 1 redundancy). A second DAB-801 may be added to implement 8 + 1 redundancy.





## Q-Sys™ Integration

Q-Sys provides enormous advantages regardless of an audio system's amplifiers or loudspeakers. But the powerful potential of Q-Sys is most fully realized when the system includes QSC loudspeakers and QSC DataPort amplifiers.

- **Amplifier integration** — When connected to QSC's PowerLight™, PL2, PL3, CX, or DCA amplifiers, the Q-Sys DataPort output card enables complete end-to-end system-level telemetry and supervision. Amplifier status, channel status, channel metering, and channel monitoring are all available for display via any Q-Sys control panel.
- **Loudspeaker integration** — Using QSC loudspeakers provides the ultimate in control and reliability by enabling functions such as driver excursion limiting and speaker fault detection. And it allows Q-Sys



Integration of QSC DataPort-equipped amplifiers is elegantly simple. Amplifier parameters may be monitored and controlled in real-time over the network using the Q-Sys™ user interface.

to maximize the sonic performance of your system. For example, when a QSC line array powered by DataPort amplifiers is connected to the Q-Sys DataPort card, you need only specify the number of cabinets and the coverage angle of the array. Q-Sys handles the rest, automatically applying the proper Intrinsic Correction™ tuning to optimize the array's acoustic performance.

## Q-Sys™ is the Solution

Q-Sys is a powerful, complete platform for audio routing, processing, and control. Far more than a collection of individual parts, Q-Sys is designed from the outset to work as an integrated whole. With a single supplier responsible for all hardware and software, deployment is smooth and performance is optimized for fast, flawless operation. And like all QSC products, Q-Sys is backed by the unrivaled support that has earned us our rock-solid reputation. Scalable, flexible, and field-proven, Q-Sys is ideal for a huge variety of applications. Whatever sort of facility you are designing — theme park or attraction, airport or transportation hub, hotel, casino, convention center, sports facility, church, corporate or educational campus, legislative or judicial chamber, or theater — Q-Sys is the integrated audio solution for you.





## QSCControl.net™ Version 3 BASIS™ | RAVE | DSP

Networked control, transport, processing and monitoring – from source to loudspeaker

QSCControl.net is a versatile foundation for networked audio systems that extend from microphone and other inputs to loudspeakers and similar outputs. QSC designed this proprietary technology expressly for system integrators, contractors, consultants and concert audio engineers who need to integrate signal processing, amplifier management and audio transport functions with QSC power amplifiers and loudspeakers. The powerful BASIS hardware platform integrates control, monitoring, protection and processing of amplifiers and loudspeakers with configurable DSP and CobraNet™ digital audio transport via Ethernet: BASIS products are the core of the QSCControl.net enabled products. QSC's RAVE units, which combine DSP functions with CobraNet digital audio transport, and the DSP 322ua dedicated signal processor, are also integral to QSCControl.net systems. BASIS, RAVE and DSP units are all programmed and controlled via QSC's Venue Manager software. Far more than digital signal transport and processing, QSCControl.net integrates the entire audio system – CX, PL2, PL3 and DCA series amplifiers as well as a growing range of loudspeaker systems including AcousticDesign™, WideLine™, ILA, and DCS products. Ideally suited for applications both large and small, the power of

QSCControl.net is the logical choice anywhere a need exists for a complete system-wide audio solution – installations such as stadiums, arenas, theatres, nightclubs, restaurants, hotels, houses of worship, corporate campuses and educational facilities, as well as large scale touring concert systems.

### Integrated Technologies

QSCControl.net combines three distinct QSC technologies of configurable DSP, amplifier/loudspeaker control and monitoring, and CobraNet audio transport into a single unified system. As noted earlier, various QSCControl.net hardware devices (BASIS, RAVE and the DSP 322ua) include functionally appropriate elements of all these technologies. All of the technologies and devices found within the QSCControl.net platform can be programmed and controlled from a single networked computer or simultaneously from multiple networked computers.

### QSCreator Custom Control Panels

QSCreator is hosted inside our Venue Manager system set up software to facilitate custom control panel creations. Control panels with a custom look and feel are designed by selecting from an extensive library of faders, knobs, buttons, meters, indicators and graphic tools. Once a control screen design has been developed, QSCreator can be established as the only software required for system operations. This prevents accidental adjustments or unauthorized tampering while keeping the control template as easy-to-use as possible.



### Network Audio Controller (NAC-100)

This fully networked wall controller adds a dimension of versatility to QSCControl.net systems. Its compact, unobtrusive design blends well with virtually any décor – convention facilities, retail environments, houses of worship and a multitude of other applications. The QSCControl.net NAC-100 can be quickly and easily programmed to build an interface that customers will understand and appreciate. The NAC-100 wall controller offers a simple, secure, cost-effective alternative to networked PC control. Multiple wall controllers can be deployed in any project and used simultaneously to manage different aspects of your system.



#### Features

- Color graphics display
- Power over Ethernet
- Recall Global Presets
- Rotary “wheel” control of an entire system
- Controllers can track each other
- Available color options black or white

### QSCControl.net System Solution

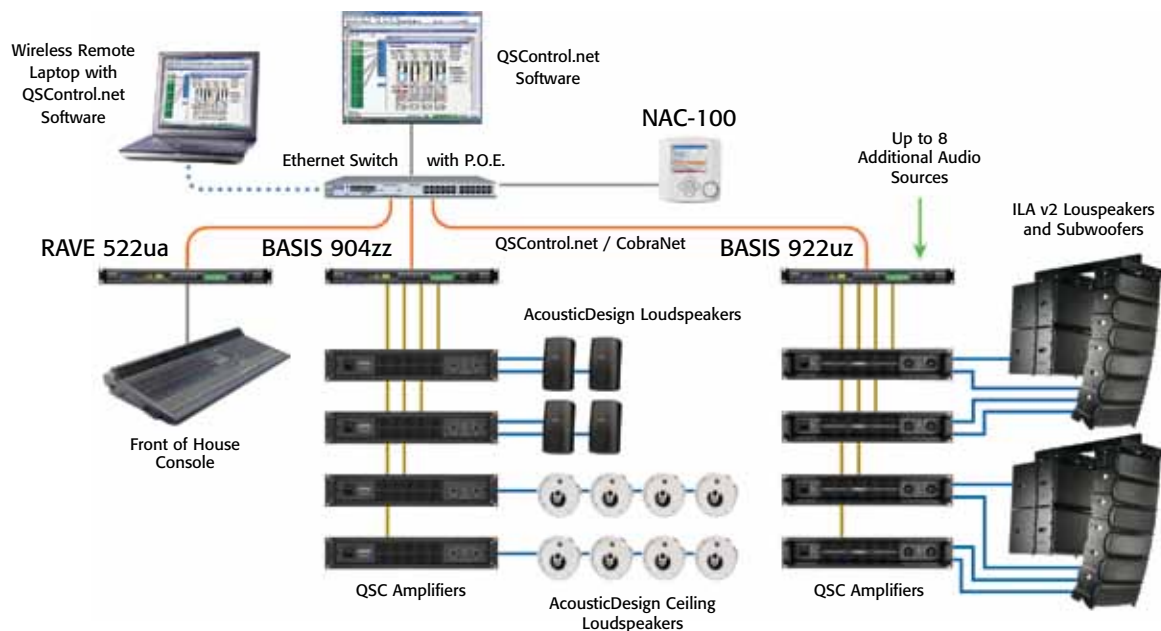

# BASIS™ | RAVE | DSP

## Powerful, Programmable Processing

The QSControl.net platform provides an extensive set of processing functions, including:

### Matrix Mixers

- Up to 24 Inputs and Outputs.

### Gain Sharing Automixing

- Facilitates any number of inputs up to 22.
- Direct outputs available for every input.
- A unique Program Reference Input automatically attenuates the selected input whenever program material is sensed.\*

\*This latter feature is especially useful for applications using several microphones, an automixer and multiple sources of program material (e.g., CD, DVD, etc.). With the Program Reference Input, the volume of the microphones can be automatically attenuated to keep the other sources from bleeding into the system.

### Routers

- Can accommodate any combination of inputs and outputs up to 24 x 24.

### Gain Controls

- Can accommodate any channel count up to 24.

### Graphic Equalizers

- Two Octave ISO
- One Octave ISO
- Two-Third ISO
- One-Third ISO
- Custom (choose number of bands, start frequency and end frequency).

### Noise Generators

- Pink noise
- White noise
- Sine generator

### Crossovers

- Linkwitz-Riley
- Butterworth
- Bessel-Thomson in-phase
- Bessel-Thomson symmetrical
- 2-way, 3-way and 4-way general purpose adjustable.

### Dynamics

- Compressor
- Peak limiter
- Dynamics processor
- Noise gate
- Automatic Gain Control – automatically boosts below-threshold signal levels up to a user-defined target output level and reduces above-threshold signal levels down to a user-defined target output level. Music, speech and custom operating modes.

### Duckers

- Up to eight channels of audio can be “ducked” simultaneously. Fade-in and fade-out times can be up to 60 seconds each. The priority channel can also be part of the ducker’s output mix.

### Filters

- High-pass, low-pass, all-pass, shelf, parametric, parametric shelf, Butterworth high and low-pass, Bessel-Thomson high and low-pass.

### Delays

- Up to 910 milliseconds.
- Units measured in time, meters, feet.

### Macros

- User-definable custom blocks with password protection.

Model	Inputs			Outputs			Monitor I/O
	Analog	Digital	CobraNet	Analog	DataPort	CobraNet	
<b>BASIS 904zz</b>	-	-	24 of 32	-	8 (16 channels)	32	YES
<b>BASIS 914lz</b>	4 XLR line level	-	16 of 32	-	8 (16 channels)	32	-
<b>BASIS 922az</b>	8 line level	-	16 of 32	-	4 (8 channels)	32	YES
<b>BASIS 922dz</b>	-	25 pin AES/EBU (8 channels)	16 of 32	-	4 (8 channels)	32	YES
<b>BASIS 922uz</b>	8 universal mic/line	-	16 of 32	-	4 (8 channels)	32	YES
<b>DSP 322ua</b>	8 universal mic/line	-	-	8 line level	-	-	-
<b>RAVE 522ua</b>	8 universal mic/line	-	16 of 32	8 line level	-	32	-

**THX**



## SC28 System Controller

The SC28 is a dedicated speaker processor with factory-optimized tunings for QSC loudspeaker systems. User-adjustable 6 band parametric equalizer, high and low shelving filters and signal delay optimize the system for acoustic, environmental or aesthetic considerations.

For uncompromised audio quality, the SC28 uses 48 kHz 24-bit A/D and D/A conversion with 32-bit floating point DSP. Advanced signal processing algorithms incorporate IIR (Infinite Impulse Response) as well as FIR (Finite Impulse Response) filters. QSC system engineers have employed the power of the SC28 System Controller's FIR filters to implement *Intrinsic Correction™* of the loudspeaker. *Intrinsic Correction* is designed to produce flat acoustical amplitude, frequency and phase response by compensating for physical phenomena such as the effects of waveguide acoustical impedance and loudspeaker cone resonance. The result is excellent power response and extremely natural, uncolored sound across the loudspeaker's frequency band and coverage area. An array of loudspeakers with *Intrinsic Correction* will be very responsive to user-applied equalization.

The SC28 is designed for simple, straightforward operation. Audio inputs and outputs are via balanced, line-level, analog XLR connectors. Four outputs for each of the two inputs are provided for use with 2 or 3-way systems plus subwoofers. Tunings are selected by scrolling through a list of QSC loudspeakers and selecting the model on the LCD panel. A similar process is used to select the QSC amplifiers being used and to configure amplifier input sensitivity for proper dynamic protection and gain structure. Settings for future QSC products can be loaded into the SC28 via a rear-mounted USB port.

Once the processor settings have been matched to the system, the user or installer can take advantage of the integral equalization and delay functions. Password protection is included to prevent unauthorized tampering.

### Intrinsic Correction™

- FIR filters optimize response in both frequency and time domains by pre-correcting for physical phenomena such as waveguide acoustical impedance and loudspeaker cone resonances.

### QSC Loudspeaker Selection

- Select the QSC loudspeaker and configuration (2-way, 3-way, 3-way + sub). The SC28 instantly reconfigures itself for optimal audio reproduction.

### QSC Amplifier Selection

- Select the QSC amplifier being used to calibrate the drive signal to the amplifier for proper balance and loudspeaker protection.

### User-Adjustable Input EQ

- Six (6) parametric filters with adjustable frequency, gain and bandwidth.
- High and low shelf filters with adjustable frequency, gain and slope.

### User-Adjustable Delays

- Sub delay adjustable from 0 to 50 ms.
- Array delay adjustable from 0 to 20 ms.

### Subwoofer Management

- Selectable stereo or mono-summed subwoofer.
- Adjustable subwoofer gain.
- System is optimized for operation with or without subwoofer.

### Loudspeaker Protection

- Optimized thermal and excursion protection for each transducer.
- User-bypassable for output clip-limiting only.

### Channel Linking

- Select linked or independent control of stereo channel settings.

### Features

- Two (2) XLR line-level inputs.
- Eight (8) XLR line-level outputs.
- Front panel meters for all inputs and outputs.
- Universal AC power input.
- Rear-panel USB port for quick and easy loading of new loudspeaker tunings.







# The New Standard



## K Series Active Loudspeakers

Entertainers | Musicians | DJs  
Concert Systems



The QSC K Series is quite simply The New Standard in lightweight powered loudspeaker systems and will satisfy the needs of the most demanding entertainers, installers and A/V users. QSC's team of amplifier engineers has created a Class D power module unparalleled in the industry. The series consists of three, bi-amplified 2-way models ranging in woofer size from 8" to 12" plus a dual 12" subwoofer.

The selection of woofer diameter and coverage for the various K Series models is not arbitrary but is based on acoustical science. K Series is designed using a concept called Directivity Matched Transition™ (DMT™). DMT matches the high-frequency coverage angle to the natural coverage of the woofer at crossover frequency. As a result, frequency response remains far more uniform across the entire audience area. The K8 delivers wide 105° coverage making it a great choice for performers who work in more intimate venues where the audience is closer to the stage and spread more widely. The more directional K12 with its 75° coverage is a better choice when more "throw" is needed. The K10, of course strikes a balance between both width and throw. All models boast the same 1000 watt power module and the same high-quality, neodymium HF driver.

Extensive DSP processing is employed throughout, providing levels of sonic clarity and total output that exceed expectations for systems of this size and weight. On-board switches select preset EQ contours. Combo XLR and 1/4" TRS inputs accept either Microphone or Line Level input while a set of RCA phono inputs (not available on KSub) allow additional connectivity to portable MP3 players, CD players and line-level mixers. Up to three audio sources can be mixed internally and summed to a balanced output for "daisy-chaining"

of multiple units. Separate direct through-puts are also provided on each channel for additional flexibility.

Full-range models are housed in rugged ABS enclosures with a professional appearance that is at home in any application. ABS is a far more robust material than conventional speaker plastics and offers sonic benefits due to its internal rigidity. Ergonomic aluminum handles and a highly protective steel grille complete the package for ease of transport and long term durability. The K12 and K10 enclosures are also designed for floor monitor use.

The K Series full-range models feature a unique Tilt-Direct™ pole cup mounting system. A simple turn of the dial engages a 7.5 degree downward tilt of the speaker allowing acoustic energy to be kept on the audience and off reflective surfaces for applications where maximum coverage from a high-positioned speaker is desired. Integrated M10 suspension points allow for suspended applications with a K Series M10 Kit (sold separately) or Yoke bracket (sold separately).

The KSub is a dual-12" bandpass design, constructed of premium birch and includes high-quality, anti-rattle casters. The subwoofer features a threaded pole receptacle for a positive, wobble-free connection to a threaded speaker pole (included).

Remote gain control capability is offered via an external potentiometer (not included) that may be wired to the on-board Euroblock connector. In an installed application, multiple K Series speakers can be "daisy-chained" for total gain control from a single remote pot. Auto-standby mode is engaged after 5 minutes of inactivity and disengages instantly when an audio signal is present.

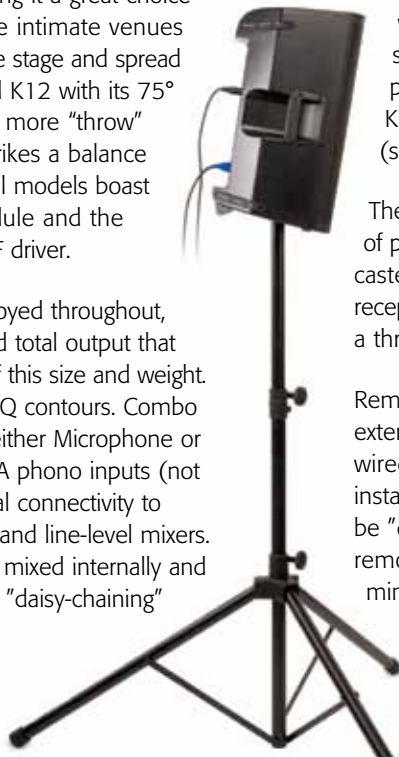

	<b>K8</b>	<b>K10</b>	<b>K12</b>	<b>KSub</b>
System Type	Trapezoidal 2-way	Multipurpose 2-way	Multipurpose 2-way	4th Order Bandpass
Frequency Range (-10 dB)	61 Hz – 20 kHz	56 Hz – 20 kHz	48 Hz – 20 kHz	44 Hz – 148 Hz
Frequency Response (-3 dB)	66 Hz – 18 kHz	60 Hz – 18 kHz	52 Hz – 18 kHz	48 Hz – 134 Hz
Nominal Coverage (-6 dB)	105° conical	90° conical	75° conical	N/A
System Performance				
Output <sup>1</sup> (Peak SPL @ 1M)	127 dB	129 dB	131 dB	130 dB
Amplifier Power	1000 W Class D	1000 W Class D	1000 W Class D	1000 W Class D
Current Consumption 1/8 Power <sup>2</sup>	100 VAC, 2.3 A • 120 VAC, 2.01 A • 230 VAC, 1.13 A			
Driver Information				
LF	8" cone transducer	10" cone transducer	12" cone transducer	2 x 12" cone transducers
HF	1.75" diaphragm compression driver	1.75" diaphragm compression driver	1.75" diaphragm compression driver	N/A
Controls / Selectors	Power • Gain A • Gain B • Channel A Input Gain (Mic/Line) • LF Mode (Ext Sub/Norm/DEEP™) • HF Mode (Flat/Vocal Boost) • Front LED (On/Off/Limit)			Power • Gain • LF Mode (Normal/DEEP™) • Polarity (Normal/Reverse) • Front LED (On/Off/Limit)
Indicator LEDs	Power • Signal A • Signal B • Standby • Limit • Mic			Power • Signal • Standby • Limit
Signal Connectors	Balanced female XLR / 1/4" mic/line level input • Balanced female XLR / 1/4" line level input • Dual Balanced male XLR full-range line level out • Balanced male XLR "mix" out • Stereo RCA line level input. Remote gain control • Locking IEC power connector			Dual balanced female XLR / 1/4" line level input • Dual Balanced male XLR full-range line level out • Remote gain control • Locking IEC power connector
AC Power Connector	Universal power supply 100 – 240 VAC, 50 – 60 Hz			
Dimensions (HWD) inches	17.7" x 11" x 10.6"	20.4" x 12.6" x 11.8"	23.7" x 14" x 14"	26" x 14" x 28.1" (including casters)
Dimensions (HWD) mm	450 mm x 280 mm x 269 mm	519 mm x 320 mm x 300 mm	603 mm x 356 mm x 356 mm	665 mm x 356 mm x 714 mm
Net Weight (each)	27 lb / 12.2 kg	32 lb / 14.5 kg	41 lb / 18.6 kg	74 lb / 33.6 kg

<sup>1</sup> Calculated for 1 m, based on sensitivity (full-space for full range systems and half-space for LF-only and subwoofer systems) and peak power capability of amplifier.  
<sup>2</sup> 1/8 power is representative of current draw with typical music program material with occasional clipping.

RoHS

### Features

- Lightweight portable powered speakers with legendary QSC amplifier power and reliability.
- 1000 watt Class D, bi-amplified power modules in all models.
- Extensive DSP enhances system performance.
- Attractive and professional appearance.
- Rugged ABS enclosures (K8, K10 and K12).
- Tour-grade 18 gauge steel grilles.
- Ergonomic handles with comfortable, non-slip grip.
- 35 mm pole sockets with Tilt-Direct™ (full-range models).
- M10 rigging points for suspended installation (full-range models).
- K10 and K12 perform as main PA or stage monitors.

### Extensive DSP

- Intrinsic Correction™, first featured in our high-end line-array products maps 65-75 spacially-averaged measurements to IIR and FIR filters that actively adjust time, frequency and amplitude response to a maximally flat bandpass target. The result is a speaker that behaves equally well across the entire sound field.
- DEEP™ and excursion limiting allow for extended low-frequency response by actively managing low-frequency transients without degradation of the underlying signal or adjacent frequencies.
- GuardRail™ protection, first introduced on our GX Series amplifiers protects both the amplifier module and your performance from unnatural and destructive clipping.

### Available K Series Accessories

- K8 TOTE
- K8 YOKE
- K8 OUTDOOR COVER
- K10 TOTE
- K10 YOKE
- K10 OUTDOOR COVER
- K12 TOTE
- K12 YOKE
- K12 OUTDOOR COVER
- KSub COVER
- K Series M10 KIT
- K Series POLE EXTENSION





## KW Series Active Loudspeakers

Entertainers | Musicians | DJs  
Concert Systems



Building on the success of our K Series, the KW Series represents the next evolutionary step in wood enclosure loudspeakers. Our system engineers have created the KW Series to feature all the same groundbreaking electronic attributes of our popular K Series while at the same time designing a product that is both smaller and significantly lighter than previous wood enclosure models.

Like K Series, each of the four KW Series models features a QSC designed, 1000 watt (2 x 500) Class D power module. And continuing in the K Series tradition, every model is fitted with the identical high-output 1.75" HF device (full-range models) and woofers of the same high quality design, regardless of speaker size.

Directivity Matched Transition (DMT™) provides for matched LF and HF coverage across the entire listening area, eliminating unnatural "dead" or "hot" frequency zones.

Extensive signal processing is employed throughout, providing levels of sonic clarity and total output that defy all expectations for a product in this category.

KW Series features a four-position mic / line gain switch that allows for connection of a wide variety of devices. Combo XLR and 1/4" TRS inputs accept both mic and line level input while a set of RCA phono inputs (except KW181) allow additional connectivity to portable MP3 players, CD players and line-level mixers. Up to three audio sources

can be mixed internally and summed to a balanced output for "daisy-chaining" of multiple units. Separate direct outputs are also provided on each channel for additional output flexibility.

On-board switches provide preset EQ settings. The HF setting (full-range models) can be set to VOCAL BOOST for additional presence in the critical midfrequency area or FLAT for accurate reproduction of the incoming signal. The LF switch can be set to NORM, DEEP™ for additional bass extension, or EXT SUB (full-range models) for use with an external subwoofer. The rear panel LED switch can be set to POWER, illuminating the front-mounted LED when the unit is powered on, OFF for applications where it is not desirable to illuminate the front LED, or LIMIT which indicates to the system operator that the clip limiter circuit has been engaged during operation.

The KW122 and KW152 feature a unique Tilt-Direct™ pole cup mounting system. A simple turn of the dial engages a 7.5 degree downward tilt of the speaker allowing acoustic energy to be kept on the audience and off reflective surfaces for applications where maximum coverage from a high-positioned speaker is desired.

Remote gain control capability is offered via a potentiometer (not included) connected to the on-board Euroblock connector. In an installed application, multiple KW Series speakers can be "daisy-chained" for total gain control from a single remote pot. Auto-standby mode is engaged after 5 minutes of inactivity.

	KW122	KW152	KW153	KW181
System Type	Multipurpose 2-way	Trapezoidal 2-way	Trapezoidal 3-way	Subwoofer
Frequency Range (-10 dB)	50 Hz – 20 kHz	43.7 Hz – 20 kHz	33 Hz – 20 kHz	39 Hz – 145 Hz
Frequency Response (-6 dB)	53.2 Hz – 18 kHz	47.4 Hz – 18 kHz	35 Hz – 18 kHz	43 Hz – 97 kHz
Nominal Coverage (-6 dB)	75° axisymmetric	60° axisymmetric	75° axisymmetric	N/A
System Performance				
Output <sup>1</sup> (Peak SPL @ 1M)	127 dB	129 dB	131 dB	130 dB
Amplifier Power	1000 W Class D (500 W LF, 500 W HF) continuous		1000 W Class D (500 W LF, 500 W MF/HF) continuous	1000 W Class D (2x 500 W) continuous
Current Consumption 1/8 Power <sup>2</sup>	100 VAC, 2.3 A • 120 VAC, 2.01 A • 230 VAC, 1.13 A			
Driver Information				
LF	12" cone transducer	15" cone transducer	15" cone transducer	18" cone transducer
MF	–	–	6.5" mid range cone transducer	–
HF	1.75" diaphragm compression driver	1.75" diaphragm compression driver	1.75" diaphragm compression driver	N/A
Controls / Selectors	Power • Gain A • Gain B • Channel A Input Gain (0 dB/12 dB/24 dB/36 dB) LF Mode (Ext Sub/Norm/DEEP™) • HF Mode (Flat/Vocal Boost) • Front LED (On/Off/Limit)			Power • Gain • LF Mode (Normal/DEEP™) • Polarity (Normal/Reverse) • Front LED (On/Off/Limit)
Indicator LEDs	Power • Signal A • Signal B • Standby • Limit • Mic (24 dB and 36 dB settings)			Power • Signal • Standby • Limit
Signal Connectors	Balanced female XLR / ¼" mic/line level input • Balanced female XLR / ¼" line level input • Dual Balanced male XLR full range line level out • Balanced male XLR "mix" out • Stereo RCA line level input • Remote gain control • Locking IEC power connector			Dual balanced female XLR / 1/4" line level input • Dual Balanced male XLR full-range line level out • Remote gain control • Locking IEC power connector
AC Power Connector	Universal power supply 100 – 240 VAC, 50 – 60 Hz			
Dimensions (HWD) inches	26" x 15" x 15.4"	32.1" x 17.5" x 15.2"	43.1" x 18.5" x 16.8"	20.1" x 23.4" x 29.9" with casters
Dimensions (HWD) mm	660 mm x 381 mm x 391 mm	816 mm x 445 mm x 386 mm	1094 mm x 470 mm x 427 mm	510 mm x 595 mm x 761 mm with casters
Net Weight (each)	49 lb / 22.2 kg	62 lb / 28 kg	87 lb / 39.5 kg	88 lb / 40 kg

1 Calculated for 1 m, based on sensitivity (full-space for full range systems and half-space for LF-only and subwoofer systems) and peak power capability of amplifier.  
2 1/8 power is representative of current draw with typical music program material with occasional clipping.

RoHS

KW Series is designed to withstand the rigors of professional use. Advanced construction processes, premium-grade Baltic birch cabinetry, ergonomic cast aluminum handles, low-noise casters (KW181) and a highly protective steel grille provide for ease of transport and long term durability. Integrated M10 suspension points allow for flown applications with a KW M10 KIT (sold separately) and a threaded pole receptacle (KW181) provides for a positive, wobble free connection to a threaded speaker pole (included).

#### Features

- K Series performance in a lightweight, birch design.
- 1000 watt Class D power modules in all models (2 x 500 W).
- Extensive DSP featuring DEEP™ and Intrinsic Correction™ enhances system performance.
- DMT™ (Directivity Matched Transition) ensures uniform coverage across the entire sound field.
- Rugged, texture-painted birch enclosures.
- Four-position Mic/Line gain (full-range models).
- Tour-grade 16 gauge steel grilles.
- Comfortable ergonomic handles.

- 35 mm pole sockets with Tilt-Direct™ (KW122, KW152).
- M10 rigging points for suspended installation (full-range models).
- KW122 also functions as stage monitor.

#### Extensive DSP

- Intrinsic Correction™, first featured in our high-end line-array products maps 65-75 spacially-averaged measurements to IIR and FIR filters that actively adjust time, frequency and amplitude response to a maximally flat bandpass target. The result is a speaker that behaves equally well across the entire sound field.
- DEEP™ and excursion limiting allow for extended low-frequency response by actively managing low-frequency transients without degradation of the underlying signal or adjacent frequencies.
- GuardRail™ protection, first introduced on our GX Series amplifiers protects both the amplifier module and your performance from unnatural and destructive clipping.

#### Available KW Series Accessories

- KW122 COVER
- KW152 COVER
- KW153 COVER
- KW181 COVER
- KW M10 KIT
- KW SUS KIT 122

Available  
Spring 2011



Examples shown  
with optional KLA  
AF12 array frame

**NEW!**

## **KLA Series Active Loudspeakers**

Fixed Arcuate, Active Line Array System

The KLA Series brings the power and sophistication of a line array system into an easy-to-use product significantly redefining the line array product category. With its simple Lift, Click and Play approach, KLA can be deployed in a fraction of the time required by comparable line array products. This fixed arcuate, active line array system is ideal for a wide range of portable and permanently installed applications ranging from live entertainment to houses of worship or other venues where a line array system is desired.

### **KLA Power Module**

The KLA Series is comprised of two models, the KLA12, a 12-inch, 2-way loudspeaker and the KLA181, 18-inch subwoofer. The KLA12 features a highly efficient 500 W x 500 W power amp module and the KLA181 offers the same highly efficient power amp module in a 1,000 W configuration. This efficient design enables up to five KLA models (any combination of KLA12 and KLA181) to be driven off of a single 15 Amp/120 V or 8 Amp/230 V electrical circuit. KLA loudspeakers incorporate QSC's DEEP™ DSP algorithm, providing extended bass response by actively managing potentially damaging low-frequency transients, and GuardRail™ circuitry protection which prevents the amplifier module from unnatural and

destructive clipping. As an energy saving feature, the Auto Standby mode automatically engages after five minutes of inactivity but upon resumption of audio signal, the power module on the KLA will awaken instantly for immediate output.

In an installed application, multiple KLA Series loudspeakers can be "daisy-chained" for total gain control from a single remote pot wired to the on-board Euroblock connector. Additional power module characteristics on KLA include a balanced, line-level XLR input in parallel with an XLR "Thru" connector, PowerCON® In and Out connectors, Attenuation Control and LED indicators for Signal, Limit and Power and Standby status.

### **KLA12**

Housed in a rugged ABS enclosure that results in both light weight and long-term durability, the KLA12 features a 12-inch low frequency transducer coupled with a 1.75-inch compression driver. Designed to be used exclusively as a fixed arcuate line array, each KLA12 is set at a 90° x 18° splay angle, allowing 90° vertical arrays to be configured using only five boxes (most other solutions require six). KLA's unique self-contained SOLO™ (Single-Operator Logistics) Rigging System enables users to quickly assemble (and disassemble) the line array in a fraction of the time as other fixed arcuate line array systems and without the need for special tools or external hardware.

	<b>KLA12</b>	<b>KLA181</b>
Configuration	Multipurpose 2-way	18" Subwoofer
Transducers		
Low-frequency	12" cone transducer	18" cone transducer
High-frequency	1.75" diaphragm compression driver	–
Frequency Response (-6 dB)	49 Hz – 18 kHz	38 Hz
Frequency Range (-10 dB)	44 Hz – 20 kHz	33 Hz
Nominal Coverage (-6 dB)	90 x 18 degree	–
Output <sup>1</sup> (Peak SPL @ 1 meter)	128 dB	135 dB
Amplifiers		
Power Output	500 W x 500 W power module	1,000 W power module
Input Impedance (Ω)	XLR: 40k balanced / 20k unbalanced	XLR: 40k balanced / 20k unbalanced
Controls	Power • Attenuation • LF Setting (External Sub/Normal/DEEP™) • Array Size (1–5) • Front LED (Pwr/Limit/Off)	Power • Attenuation • LF Mode (Normal/DEEP™) • Polarity (Normal/Reverse) • Front LED (Pwr/Limit/Off)
Indicators	Limit • Standby • Power • Signal	
Connectors	Balanced female XLR line level input • Balanced male XLR full range line level out • Remote attenuation control • Locking PowerCON power connector AC In • Locking PowerCON power connector AC Out	
Cooling	On demand, 50 mm variable speed fan	
Amplifier Protection	Thermal limiting • Output overcurrent • Overtemperature muting • GuardRail™	
Transducer Protection	Thermal limiting • Excursion limiting	
AC Power Input	Universal power supply 100 - 240 VAC, 50 - 60 Hz	
AC Power Consumption 1/8 Power <sup>2</sup>	100 VAC, 2.3 A • 120 VAC, 2.01 A • 230 VAC, 1.13 A	
Enclosure	Impact resistant ABS	Painted birch plywood
Finish	Black or White Paint	Black or White textured paint
Grille	Black or White powder coated 18 gauge steel	
Dimensions (HWD)	15.0" x 23.4" x 16.6" (382mm x 594mm x 422mm)	21.6" x 23.1" x 25.7" (547mm x 586mm x 653mm)
Weight (Net)	54 lbs / 25 kg	100 lbs / 45.3 kg
Available Accessories	KLA12 TOTE • K Series M10 KIT • KLA AF12 Array Frame	KW181 Pole

<sup>1</sup> Calculated for 1 m, based on sensitivity (full-space for full range systems and half-space for LF-only and subwoofer systems) and peak power capability of amplifier.

<sup>2</sup> 1/8 power is representative of current draw with typical music program material with occasional clipping.

RoHS

KLA12's Ar-Q™ (Arcuate Equalization) processing enables users to quickly tune the array, making appropriate frequency compensation adjustments based on the number of boxes. With the click of a dial, the user can select the total number of boxes deployed in the array resulting in an evenly balanced and accurate tonal curve. QSC's proprietary Intrinsic Correction™, first introduced with the Wideline™ Series, actively adjusts time, frequency and amplitude response to achieve a maximally flat bandpass target.

### KLA181

In addition to DEEP™ DSP algorithm, GuardRail™, Auto Standby, balanced line-level XLR input with an XLR "Thru" connector, Attenuation Control and LED indicators, the KLA181 subwoofer also includes a polarity switch for low frequency directivity control.



### Rigging & Deployment

For maximum deployment flexibility, KLA loudspeakers can be either ground deployed or flown. As a ground stack, up to two KLA12 enclosures can be mounted over the KLA181 or the KW181 subwoofer via a threaded pole socket, or without a sub using an appropriately rated loudspeaker stand. KLA12 enclosures also feature the Tilt-Direct™ 35mm pole socket allowing the loudspeaker to be aimed downward 9° for the best audience coverage.

Up to five KLA enclosures (any combination of KLA12 and KLA181) can be flown via M10 fittings on the top of each enclosure. An optional KLA AF12 array frame is also available.

#### Available KLA Series Accessories

- KLA12 TOTE
- KLA AF12 Array Frame
- KLA Series M10 KIT



## ILA Series v2 Installation Line Array

Installed Sound

Most line array systems are designed for touring applications which require extreme ruggedization and expensive suspension hardware. By focusing on installation applications QSC drove cost out of the ILA System while retaining the performance of high-end touring line array systems. ILA System v2 takes this concept and builds on it by offering a complete and accessible solution consisting of processing, amplification, line array, subwoofer and suspension accessories.

### WL2082-i

Each Installation Line Array element uses a pair of high-power, neodymium magnet, 8" diameter low-frequency drivers. For high frequencies, a pair of 1.75" (voice coil diameter) neodymium compression drivers with titanium domes are mounted on a patented\* multiple aperture diffraction waveguide that provides extremely wide coverage (140°). As a result, a WL2082-i system will rarely require additional side or center fill speakers and solid stereo imaging is preserved across the entire listening area.

Available in black or white, the WL2082-i enclosure is made of high impact polystyrene with extensive internal ribs to eliminate acoustic losses due to sidewall flex. The Installation Line Array may be used in outdoor applications where the system is not directly exposed to the elements.

### WL118-sw Subwoofer

The WL118-sw is a single 18" version of the popular WideLine-10 touring, dual 18" subwoofer. ILA subs may be suspended at the top of an ILA array using the standard FB2082-i array frame. When trim height is limited, the ILA sub may be suspended behind the array using the available EB2082-i extension bar.

\*Patent No. 7,177,437



WL2082-i with WL118-sw using EB2082-i extension bar and FB2082-i fly-bar.

### GP118-sw Subwoofer

The GP118-sw omits the ILA compatible suspension hardware but retains the identical acoustical performance of the WL118-sw at a lower cost. Each GP118-sw includes a total of eight (8) threaded M10 inserts for single box suspension in permanent installations. In ground-supported applications, multiple units can be stacked vertically utilizing the interlocking feet and recess features machined into the enclosures top panel. Also included on the GP version is a screw-in (M20) pole mount to provide flexibility as a "Sub-Sat" system when used with full-range pole mount speakers such as K or KW.



GP118-sw



	WL2802-i	GP118-sw	WL118-sw
System Type	3-way line array element, Bi-amp or Tri-amp	Vented box, direct radiating	Vented box, direct radiating
Frequency Range (-10 dB)	68 Hz – 22 kHz	29 Hz – 800 Hz	29 Hz – 800 Hz
Frequency Response (±3 dB)	80 Hz – 20 kHz	32 Hz – 200 Hz	32 Hz – 200 Hz
Nominal Coverage	140° H	N/A	N/A
Power Handling <sup>1</sup> LF / MF / SUB	400 W	1000 W	1000 W
HF	100 W	N/A	N/A
Peak Output <sup>2</sup>	132 dB	134.5 dB	134.5 dB
Driver Information LF	2 x 8" transducers; 2" voice coil; neodymium magnet	18" transducer, 4" voice coil, ferrite magnet	18" transducer, 4" voice coil, ferrite magnet
HF	2 x 1.75" titanium diaphragm, neodymium magnet	N/A	N/A
Controls / Selectors	Bi-amp/tri-amp selector switch, LF/MF shading switch	N/A	N/A
Input Connectors	2 x NL8 in parallel	2 x NL8 in parallel and 2 x NL4 in parallel	2 x NL8 in parallel and 2 x NL4 in parallel
Suspension / Attachment Point	Integral rigging system, vertical splay adjustable in 1 degree increments from 0-10 degrees	8 x M10 threaded inserts	Integral, non-adjustable (straight array only)
Dimensions (HWD) inches	11.8" x 27" x 13.4"	22.1" x 27.6" x 30.3"	22.1" x 27.6" x 30.3"
Dimensions (HWD) mm	300 mm x 686 mm x 340 mm	562 mm x 702 mm x 771 mm	562 mm x 702 mm x 771 mm
Net Weight (each)	37 lb / 16.8 kg	107 lb / 48.5 kg	111 lb / 50.4 kg

<sup>1</sup> Continuous IEC specified test signal, 2 hours.

<sup>2</sup> Calculated at 1 m using power capacity and system sensitivity. 6 dB peak-to-average signal ratio assumed.

RoHS



## Processing

The SC28 is a 2 input, 8 output digital system controller containing pre-programmed tunings for the ILA and other QSC loudspeaker systems. In addition to the preset tunings, the SC28 offers user-adjustable equalization and delay. Simple to operate yet uncompromised in audio quality, the SC28 uses 48 kHz, 24-bit A/D and D/A conversion with 32-bit, floating point DSP for wide dynamic range and low distortion.

## Available ILA Accessories

- FB2082-i: Fly-bar, may be used with either WL2082-i or WL118-sw.
- EB2082-i: Extension bar allows suspending WL118-sw behind WL2082-i.
- PB2082-i: Pullback bar for WL2082-i.
- QRP-KIT-1: Four quick release pins, for use in place of included bolts.
- GS115-sw: Ground stack kit for WL118-sw.
- AB2082-i: Allows increased splay between enclosures.

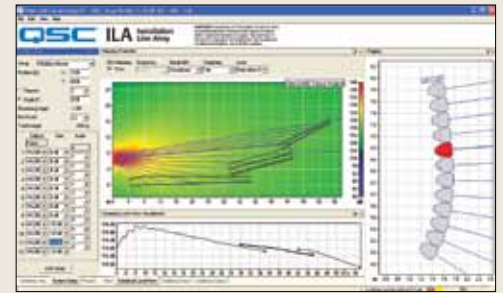

## EASE Focus Software

This free software may be downloaded from the support section of the QSC website and is available for ILA, WideLine-10 and WideLine-8.

EASE Focus is a software tool that aids in system planning and deployment. Functions performed include:

- Calculating the number of enclosures required for a given space.
- Determining optimum splay angles between enclosures.
- Calculating the angle to set the array grid in a single (variable) pick-point or fixed suspension point application.
- Predicting the acoustical response and SPL throughout the venue.

## The ILA v2 System

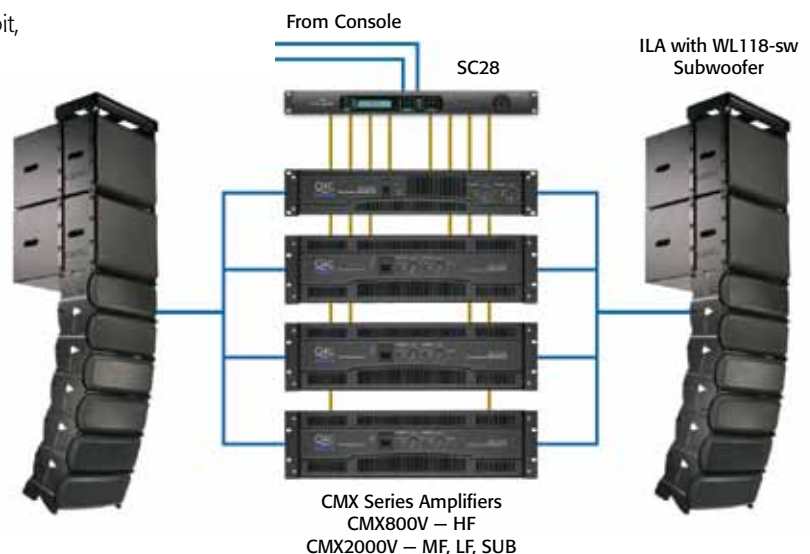

WL3082 shown hung  
from AF3082-S.



## WideLine-8 Line Array System

Concert Systems  
Installed Sound

### WL3082

Designed for the most demanding concert and installation audio professionals, the WideLine™ WideLine-8 system packs full size line array performance into an ultra compact package measuring less than 20" (508 mm) wide and 9" (229 mm) high. WideLine-8 fits "difficult" venues with height or sightline restrictions that limit the placement and size of the array. It eases transport requirements to avoid rising fuel costs.

Each tri-amplified WideLine-8 element uses a pair of high-power neodymium 8" low-frequency drivers. Both generate the low frequencies, but to maintain wide 140° horizontal coverage at crossover, only one extends into the mid-range. High frequencies are handled by a 3" diaphragm, neodymium compression driver on QSC's patented\* multiple aperture diffraction slot waveguide. Enclosures are Baltic birch plywood with an environmentally friendly, field-repairable waterborne polymer finish and lightweight, rustproof aluminum suspension fittings.

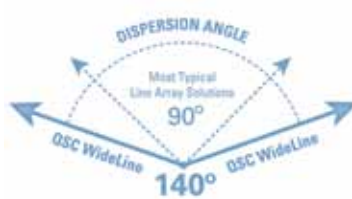

### Flexible Arrays

An elegantly simple 4-point suspension system combined with light weight, compact size and excellent handling ergonomics mean that one crewperson can easily deploy an array. A single AF3082-L array frame suspends up to twelve line array elements or up to twelve line array elements plus four subwoofers.

Arrays can be assembled using only WL3082 elements for events where extreme low end below 62 Hz is not required. For additional subbass impact, WL212-sw subwoofers can be flown at the top of the array, or behind the fullrange array by utilizing the EB3082 extension bar.

Arrays of up to twelve WL3082 modules, with four WL212-sw subwoofers flown behind can be accommodated by the combination of 2 x AF3082-S small array frames and a single EB3082 extension bar. As many as twelve WL3082 modules can be suspended using one AF3082-S while the AF3082-L large array frame can be used to assemble arrays of up to twelve WL3082 modules alone or suspended below up to four WL212-sw subwoofers. The AF8-10 adapter frame allows the user to add WL3082 WideLine-8 arrays beneath WL2102 WideLine-10 arrays. The PB3082 pullback bar can be used to attain extra downangle in flown arrays or as a suspension bar for arrays of up to eight WL3082 modules.

\*Note: In application where the AF3082-S (small array frame) is utilized, a PB3082 (pull-back bar) will be required for setting the array angle (focusing) of each array.

\*Patent No. 7,177,437



Six WL3082 shown with two WL212-sw behind array, hung from two AF3082-S and one EB3082.



<b>WL3082</b>	
System Type	Dual 8", 3-way, tri-amp line-array
Frequency Range (-10 dB)	62 Hz – 20 kHz
Frequency Response ( $\pm 3$ dB)	68 Hz – 18 kHz
Nominal Coverage	140° H
Power Handling <sup>1</sup> LF / MF / HF	250 W / 250 W / 85 W
Peak Output <sup>2</sup> LF / MF / HF	128 dB / 128 dB / 133 dB
Driver Information LF	Dual, 8" woofer, 2.5" voice coil
HF	1.4" exit, 3" diaphragm, neodymium magnet compression
Input Connectors	NL8 x 2
Suspension / Attachment Point	Integral rigging system, vertical splay adjustable in 1° increments from 0°- 10°
Dimensions (HWD) inches	9" x 20" x 16"
Dimensions (HWD) mm	229 mm x 508 mm x 406 mm
Net Weight (each)	38 lb / 17 kg

<sup>1</sup> Continuous IEC specified test signal, 2 hours unless otherwise stated.  
<sup>2</sup> Calculated at 1 m using power capacity and system sensitivity.  
 6 dB peak-to-average signal ratio assumed.

**RoHS**

### Optimized Groundstacking

The WideLine-8 system can be flown or ground stacked. WideLine-8 rigging doubles as an optimized groundstacking system. The WideLine-8 sub suspension system includes a unique provision that allows the lowest line array element stacked over a sub to be tilted up or down by as much as 10°, offering better coverage of listeners near the stage. WideLine-8 subs can be used as a base for stacking up to six WideLine-8 elements.

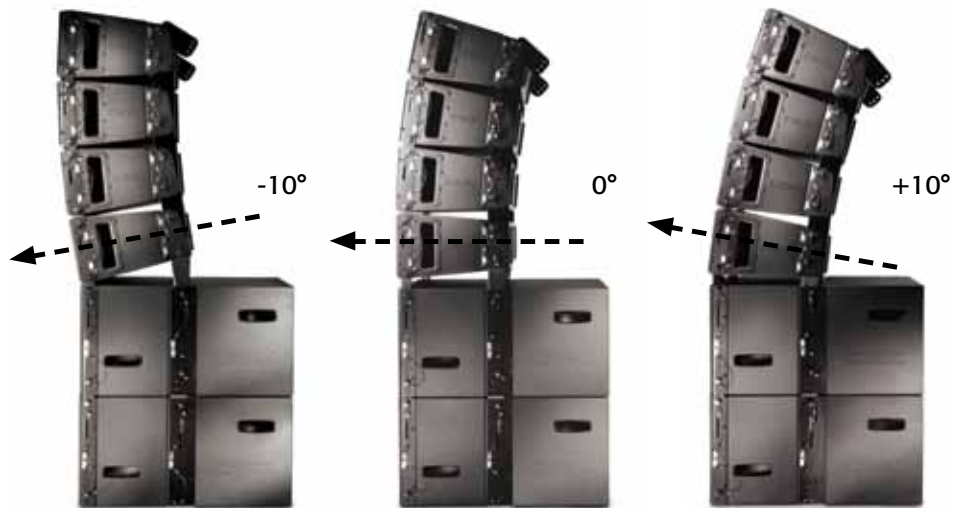

Four WL3082 on top of two WL212-sw.



WL212-sw



GP212-sw

## WideLine-8 Subwoofers

Concert Systems  
Installed Sound

The WL212-sw, WideLine-8 Subwoofer, and the GP212-sw are acoustically identical subwoofers, differing primarily in suspension hardware. Both subwoofers set a new benchmark for extraordinary acoustic output from a miniscule enclosure. At first glance, the enclosure seems too small for a pair of 4" voice coil, long excursion 12" woofers. The extremely low profile (under 15" / 38 mm) also makes the WL212-sw sub a great choice for installed and portable use under a stage or in other tight quarters. The 4th order bandpass design produces 135 dB peak SPL and has LF extension to 32 Hz – all the power and punch needed for popular music.

### WL212-sw

Enclosure width matches the WL3082 (WideLine-8) allowing it to be flown above or behind a WideLine-8 array. Adding WL212-sw subwoofers to tri-amplified WL3082 arrays creates a 4-way active system. A WideLine-8 system can be flown or ground stacked. WideLine-8 rigging doubles as an optimized ground-stacking system. The WL212-sw suspension system includes a unique provision that allows the lowest line array element stacked over a sub to be tilted up or down by as much as 10°, offering better coverage of listeners near the stage. WideLine-8 subs can be used as a base for stacking up to six WideLine-8 elements.

### GP212-sw

The GP212-sw omits the WideLine-8 compatible suspension hardware but retains all the acoustical performance of the WL212-sw at a lower cost. For suspension in permanent installations each GP212-sw subwoofer includes a total of six (6) threaded M10 inserts. For ground-supported applications, the subwoofers may be stacked horizontally using their interlocking feet and recess features machined into the enclosure's top panel. A screw-in (M20) pole mount has been added to provide flexibility in use with small 2-way pole mount full-range speakers.

#### Both Models

- Dual 12" woofers in a 4th order band-pass enclosure.
- 135 dB SPL peak output capability.
- 32 Hz – 107 Hz frequency range.
- Premium birch plywood with extensive internal bracing.

#### WL212-sw

- May be flown at the top of a WL3082 array or behind the array.
- Integral suspension hardware also supports WL3082 in ground stack applications.

#### GP212-sw

- Six (6) threaded M10 flypoints for suspended applications.
- M20 threaded pole-socket for sub/sat use.



	GP212-sw	WL212-sw
System Type	Dual 12", 4th order bandpass subwoofer	Dual 12", 4th order bandpass subwoofer
Frequency Range (- 10 dB)	32 Hz – 107 Hz	32 Hz – 107 Hz
Frequency Response ( $\pm 3$ dB)	40 Hz – 100 Hz	40 Hz – 100 Hz
Power handling <sup>1</sup>	1100 W	1100 W
Peak output <sup>2</sup>	135 dB	135 dB
Driver Information LF	Dual 12" transducers, 4" voice coil, ceramic magnet	Dual 12" transducers, 4" voice coil, ceramic magnet
Input Connectors	2 x NL8 in parallel & 2 x NL4 in parallel	2 x NL8 in parallel & 2 x NL4 in parallel
Suspension / Attachment Point	6 x M10 threaded inserts	Integral, non-adjustable
Dimensions (HWD) inches	15" x 20" x 29"	15" x 20" x 29"
Dimensions (HWD) mm	381 mm x 508 mm x 737 mm	381 mm x 508 mm x 737 mm
Net Weight (each)	99.5 lb / 45.1 kg	109 lb / 49.4 kg

<sup>1</sup> Continuous IEC specified test signal, 2 hours unless otherwise stated.

<sup>2</sup> Calculated at 1 m using power capacity and system sensitivity. Assumed 6 dB peak-to-average signal ratio.

RoHS

Two WL212-sw shown hung from AF3082-L with six WL3082 hung beneath.



### Available WideLine-8 Accessories

- AF3082-L: Large array frame, supports up to twelve (12) WideLine-8 elements and four (4) WideLine-8 subs with 10:1 design factor.
- AF3082-S: Small array frame, supports up to twelve (12) WideLine-8 elements with 10:1 design factor.
- AF8-10: Adapter frame that allows suspension of WL3082 under WL2012.
- EB3082: Extension bar, required for system with the subwoofers flown behind the main array.
- PB3082: Allows extra down-angle in flown arrays and functions as a suspension bar for small WL3082 arrays.
- CP3082-4: Caster pallet for four (4) WL3082 line array elements, includes a padded soft cover.
- CP212-0: Caster pallet for up to four (4) WL212-sw or GP212-sw.
- CVR212-2: Soft padded cover for two (2) WL212-sw or GP212-sw.
- CP212-2: Caster pallet for two (2) WL212-sw or two (2) GP212-sw, includes a padded soft cover.

CP212-2



GP212-sw shown with KW122



CP3082





## WideLine-10 Line Array System

Concert Systems  
Installed Sound

### WL2102-w

The WideLine™ WL2102-w is a compact, high-output, wide dispersion line array loudspeaker system renowned for its ability to meet and exceed requirements for applications ranging from corporate meetings to large venue reinforcement of high-level popular music. From ballrooms to churches to concert venues, WideLine-10 provides full-range, warm, open, natural sound with exceptionally wide horizontal coverage (140°).

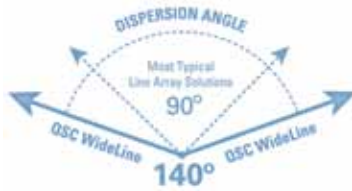

Wide coverage provides more latitude in array placement and may reduce or eliminate the need for supplemental fill speakers.

Each WideLine-10 array element consists of two 10", long-throw, low-frequency drivers in a ported trapezoidal, premium quality birch plywood enclosure. The high-frequency component is a 3" diaphragm, neodymium high-frequency driver mounted on QSC's patented\* multiple aperture diffraction slot waveguide.

Both LF transducers handle low frequencies, but only one extends into the mid-frequencies thus reducing phase and coverage anomalies in the critical crossover region. The system may be operated in either bi-amplified or tri-amplified mode.

A strong emphasis has been placed on reduction of system setup time and labor costs. Two array grids are available: The small grid supports up to 8 flown enclosures or 4 stacked; the large array frame supports up to 24 flown or 12 stacked.

WL2102-w shown hung  
from AF2102-LA.



\*Patent No. 7,177,437



<b>WL2102-w</b>	
System Type	3-way line array element, Bi-amp or Tri-amp
Frequency Range (-10 dB)	48 Hz – 20 kHz
Frequency Response ( $\pm 3$ dB)	55 Hz – 18 kHz
Nominal Coverage	140° H
Power Handling <sup>1</sup> LF / MF	600 W
HF	80 W
Peak Output <sup>2</sup> LF / MF	133 dB / 133 dB
Driver Information LF	2 x 10" transducer, 3" voice coil, ferrite magnet
HF	3" titanium diaphragm, neodymium magnet
Controls / Selectors	Bi-amp/tri-amp selector switch, LF/MF shading switch
Input Connectors	NL8 x 2
Suspension / Attachment Point	Integral rigging system, vertical splay adjustable in 1° increments from 2°- 10°, plus 0°
Dimensions (HWD) inches	10.8" x 27.4" x 20.75"
Dimensions (HWD) mm	274 mm x 696 mm x 527 mm
Net Weight	WL2102-w: 83 lb / 37.7 kg

<sup>1</sup> Continuous IEC specified test signal, 2 hours bi-amp mode unless otherwise stated.  
<sup>2</sup> Calculated at 1 m using power capacity and system sensitivity, 6 dB peak-to-average signal ratio assumed.

RoHS

#### Available WideLine-10 Accessories

- WL Small Grid: May be used to stack four (4) or fly eight (8) WL2102-w.
- AF2102-LA: May be used to stack twelve (12) or fly twenty-four (24) WL2102-w.
- WL-10 Eight-Pack Rack: Transport/storage unit, accommodates eight (8) WL2102-w plus one AF2102-LA.
- AF8-10: Adapter frame that allows suspension of WL3082 under WL2012-w.



Empty WL-10 Eight Pack Rack.



Fully loaded WL-10 Eight Pack Rack.

Four WL218-sw shown hung from AF218-sw.



WL218-sw array shown with a combination WideLine-10 and WideLine-8 array.



## WideLine-10 Subwoofers

Concert Systems  
Installed Sound

The WL218-sw and the GP218-sw are premium, high-performance dual 18" subwoofers designed for use in the most demanding touring or installed concert applications. They are acoustically identical subwoofers, differing primarily in suspension hardware.

With an impressive combination of punch, low-frequency extension and musical accuracy, these subwoofers are ideal companions for the acclaimed QSC WideLine™ Series as well as other professional sound reinforcement systems. The 18" woofers incorporate a double layer spider and triple roll surround for extended and controlled excursion at extreme power. The 4" voice coil is wound on a fiberglass former to prevent deformation at high operating temperatures and is extensively vented to reduce power compression. Both enclosures are constructed of premium quality birch plywood with extensive internal bracing and finished to stand up to heavy use.

### WL218-sw

The WL218-sw can be flown or ground stacked. Using the AF218-sw array frame, up to eight WL218-sw subwoofers may be suspended with a 10:1 design factor. The subwoofers may be stacked vertically using

the interlocking feet and recess features. For ease of transport, the WL218-sw includes a caster pallet with rugged 3.5" ball bearing casters and an easy-to-use, snap-on mechanism for attachment to the enclosure.

### GP218-sw

The GP218-sw omits the WL218-sw suspension hardware and trapezoidal shape but retains all the acoustical performance of the WL218-sw at a lower cost. For ground-supported applications, the subwoofers may be stacked horizontally using their interlocking feet and recess features machined into the enclosure's top panel. For suspension in permanent installations each GP218-sw subwoofer includes a total of sixteen (16) threaded M10 inserts. An optional transport caster pallet is available.



GP218-sw



	<b>GP218-sw</b>	<b>WL218-sw</b>
System Type	2 x 18" vented subwoofer	2 x 18" vented subwoofer
Frequency Range (-10 dB)	27.4 Hz – 1.2 kHz (without processing)	31 Hz – 1 kHz (without processing)
Frequency Response ( $\pm 3$ dB)	31.4 Hz – 240 Hz (without processing)	37 Hz – 200 Hz (without processing)
System Performance		
Power handling <sup>1</sup>	1700 W	1700 W
Peak output <sup>2</sup>	140.5 dB	139 dB
Driver Information LF	Dual 18" transducers, 4" voice coil, ceramic magnet assembly	Dual 18" transducers, 4" voice coil, ceramic magnet assembly
Input Connectors	2 x NL4 in parallel	2 x NL4 in parallel
Suspension / Attachment Point	16 x M10 threaded inserts	Integral rigging system, vertical splay adjustable in 1° increments from 0° - 10°
Dimensions (HWD) inches	20" x 47.17" x 30"	21.3" x 45.9" x 34.75"
Dimensions (HWD) mm	508 mm x 1198 mm x 762 mm	541 mm x 1166 mm x 882 mm
Net Weight (each)	191 lb / 86.6 kg – speaker only	204 lb / 92.5 kg – speaker only 244 lb / 110 kg – includes dolly

<sup>1</sup> Continuous IEC specified test signal, 2 hours unless otherwise stated.

<sup>2</sup> Calculated at 1 m using power capacity and system sensitivity. Assumed 6 dB peak-to-average signal ratio.

RoHS

### Available WideLine-10 Subwoofer Accessories

- AF218-sw: Array frame.
- CVR218: Soft cover for WL218-sw.
- CVRGP218: Soft cover for GP218-sw.
- CP218-0: Caster pallet for GP218-sw.
- CP218-1: Caster pallet for GP218-sw, includes a padded soft cover.

For the WL218-sw the caster pallet is included.



CP218-0 caster pallet.



CP218-1 caster pallet with soft cover.

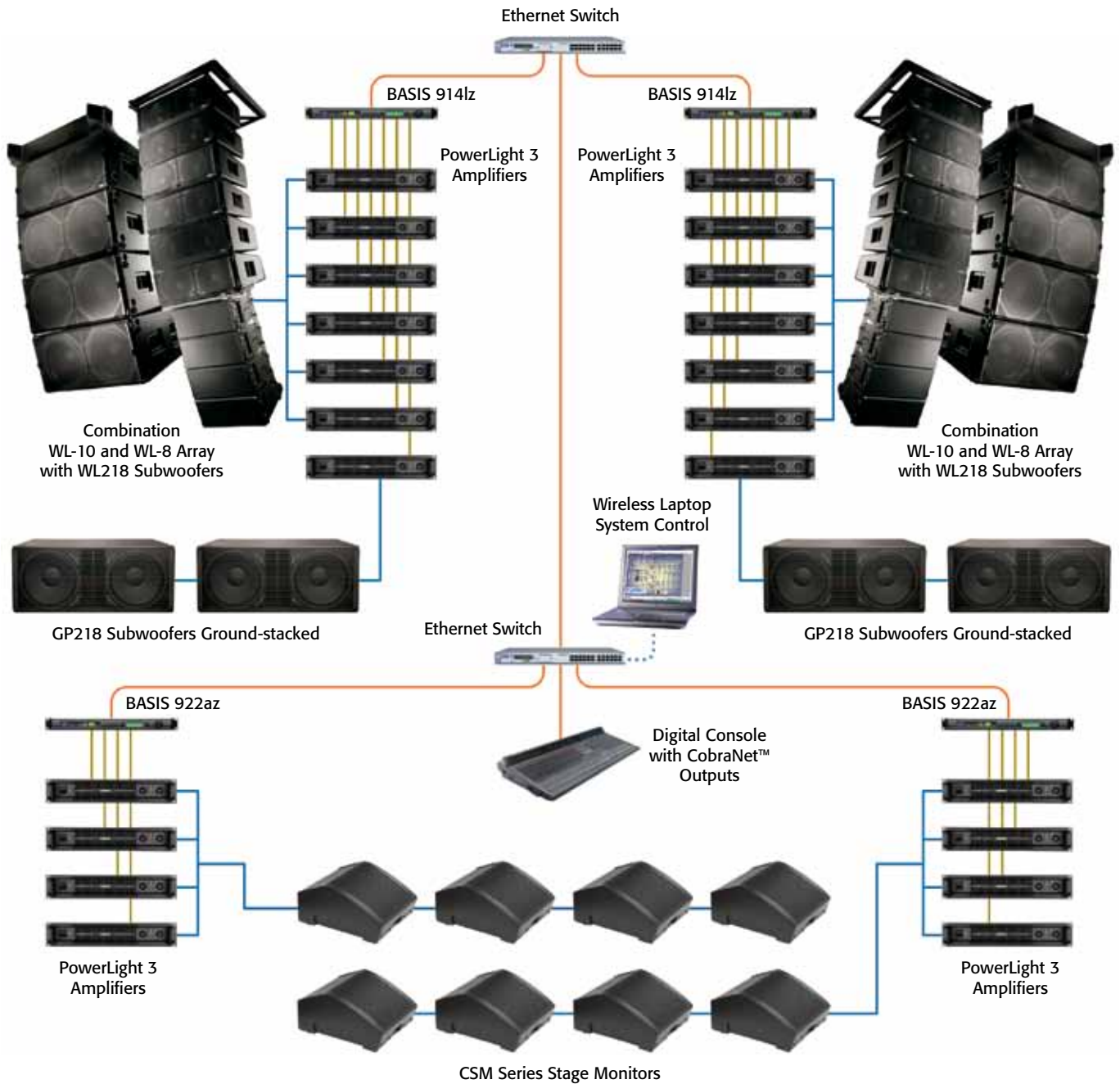

## Fully Networked Concert System Solutions

QSC Concert Systems offer the highest degree of flexibility while providing maximum use and scalability in inventory management. Using QSCControl.net digital processors throughout the system allows the user to easily reconfigure and combine multiple speaker systems at a "click of the mouse", while maintaining full system remote control and monitoring of the entire "front to back" audio chain via wired and/or wireless PC control.



BASIS 922az, PL325 and PL380 amplifiers.

**NEW!**

## WLWX Weatherized WideLine™

### Installed Sound

#### WL2102-wx

The WL2102-wx is a weather resistant, installation version of the WideLine-10 WL2102-w line array. All portable rigging hardware is removed and replaced with four female M10 fittings (eight total) mounted to either end of the enclosure. The loudspeaker is designed for 3-way operation only and no handles are provided. An adjustable, external, bolt-on rigging system for box-to-box connection and adjustment of splay angles is included.

The AF2102-wx is a compatible, aluminum array frame for use when suspending the WL2102-wx. Array frames for the standard WL2102-w are not compatible with the WL2102-wx.

#### WL3082-wx

The WL3082-wx is a weather resistant, installation version of the WideLine-8 WL3082 line array. All portable rigging hardware is removed and replaced with four female M10 fittings (eight total) mounted to either end of the enclosure. The loudspeaker is designed for 3-way operation only. An adjustable, external, bolt-on rigging system for box-to-box connection and adjustment of splay angles is included.

The AF3082-wx is a compatible, aluminum array frame for use when suspending the WL3082-wx. Array frames for the standard WL3082 are not compatible with the WL3082-wx.

#### GP218-wx

The GP218-wx is a weather resistant, installation version of the WideLine-10 GP218 subwoofer. The standard version includes no suspension provisions but M10 suspension points may be added on request.

#### Enclosure Construction

WideLine-wx models are constructed using premium birch plywood which is full encapsulated in fiberglass. The input connector plate is replaced by a hardwired, captive, UV resistant, outdoor-rated (direct burial) cable with a gland-nut through the cabinet for water-proofing. The cable will be 3 meters in length unless otherwise specified at the time the order is placed. Grilles are stainless steel, covered in outdoor rated, vinyl coating and lined with acoustic foam and a fine woven stainless steel mesh.

#### Delivery

WideLine WX models are strictly built to order. Please allow 90 days plus shipping time from the time the P.O. is received by QSC for delivery.

	WL2102-wx	WL3082-wx	GP218-wx
System Type	Tri-amp line array element	Tri-amp line array element	2 x 18" vented subwoofer
Frequency Range (-10 dB)	48 Hz – 20 kHz	62 Hz – 20 kHz	27.4 Hz – 1.2 kHz (without processing)
Frequency Response (±3 dB)	55 Hz – 18 kHz	68 Hz – 18 kHz	31.4 Hz – 240 kHz (without processing)
Nominal Coverage	140° H	140° H	N/A
Power Handling <sup>1</sup>			
LF / MF	600 W	250 W	1700 W
HF	80 W	85 W	N/A
Peak Output <sup>2</sup>			
LF / MF	127 dB / 133 dB	122 dB / 128 dB	140.5 dB
Driver Information			
LF	2 x 10" transducer, 3" voice coil, ferrite magnet	2 x 10" transducer, 3" voice coil, ferrite magnet	2 x 18" transducers, 4" voice coil, ceramic magnet
HF	3" titanium diaphragm, neodymium magnet	3" titanium diaphragm, neodymium magnet	N/A
Input Connectors	Tinned, bare wire	Tinned, bare wire	Tinned, bare wire
Suspension / Attachment Point	Integral rigging system, vertical splay adjustable in 1° increments from 0°-10°	Integral rigging system, vertical splay adjustable in 1° increments from 0°-10°	None (M10 points available by request)
Dimensions (HWD) inches	11.75" x 27.25" x 18.5"	9.5" x 20" x 15.5"	21.13" x 30.13" x 47.32"
Dimensions (HWD) mm	298 mm x 692 mm x 470 mm	241 mm x 508 mm x 394 mm	537 mm x 765 mm x 1202 mm
Net Weight	92.5 lb / 42 kg	61 lb / 27.7 kg	215 lb / 97.5 kg

<sup>1</sup> Continuous IEC specified test signal, 2 hours bi-amp mode unless otherwise stated.

<sup>2</sup> Calculated at 1 m using power capacity and system sensitivity. 6 dB peak-to-average signal ratio assumed.

**RoHS**

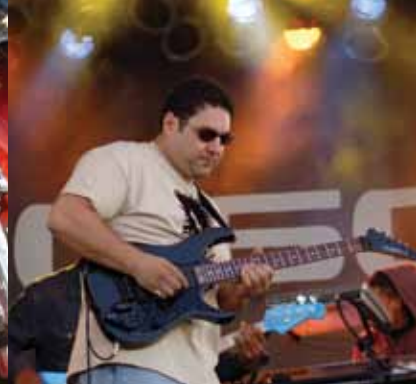

## CSM Series Concert Stage Monitor Systems

Concert Systems

### CSM10 | CSM12 | CSM15

The CSM Series are “system packages” comprised of stage monitor loudspeakers, proprietary digital processing and high-power amplifiers in a tightly integrated design that offers the highest output to size ratio of any premium brand stage monitor on the market to date. Combining elegant industrial design with state of the art driver and waveguide technology, these very low-profile wedges embody all the contemporary attributes asked for by today’s most demanding monitor engineers. Achieving all this requires very specific power and digital processing. The amazing performance of the CSM models is a result of extensive and sophisticated application of digital signal processing. The processing algorithms can not be readily replicated on other DSP platforms. CSM Series are designed only for use with the appropriate QSC processing using a digital controller from the QSCControl.net™ series of processors.

### Selectable Coverage Pattern

CSM monitors utilize a selectable pattern control “shutter” system that enables the user to limit the amount of high-frequency energy spilling over into the audience, while increasing its upstage coverage angle. By opening the shutter, the vertical coverage is converted to an asymmetrical pattern of +45° and -75° off axis, while maintaining a nominal 50° pattern

in the horizontal. With the shutter closed, the enclosure can be used as a wide coverage 150°H x 50°V utility fill speaker.

### Internal Angle Adjusters

In addition to the generous upstage coverage of the CSM waveguide, special integral hardware provides up to an additional 15°, in 1° increments, of angle to the enclosure to gain more extreme upstage coverage.



### Hidden and Protected Connectors

One of the problematic conditions that have long plagued most stage monitor designs is the location of the input and output speaker connections. If they are located on the sides, they can often be in the way when placing multiple monitors side by side. If they get mounted on the down-stage side (facing the audience), they tend to become unsightly and cluttered in view from the audience. If they are placed on the up-stage side (facing the musician), they tend to wind up under the performers feet and often get damaged or broken during performances.



	CSM10	CSM12	CSM15
System Type	2-way wedge	2-way wedge	2-way wedge
Frequency Range (-10 dB)	70 Hz – 20 kHz	55 Hz – 20 kHz	45 Hz – 20 kHz
Frequency Response ( $\pm 3$ dB)	80 Hz – 20 kHz	65 Hz – 20 kHz	55 Hz – 20 kHz
Nominal Coverage (-6 dB)			
Wedge	50° H x +45°/-75° V	50° H x +45°/-75° V	50° H x +45°/-75° V
Multipurpose	150° H x 50° V	150° H x 50° V	150° H x 50° V
Power Handling (Continuous)			
Passive	450W	550W	650W
Low-frequency	450W	550W	650W
High-frequency	110W	110W	110W
Sensitivity (SPL 1 W at 1 m)			
Passive	95 dB	96.5 dB	98 dB
Low-frequency	95 dB	96.5 dB	98 dB
High-frequency	108 dB	108 dB	108 dB
Max Calculated Output (SPL at 1 m)			
Passive	128 dB	130 dB	131.5 dB
Low-frequency	128 dB	130 dB	131.5 dB
High-frequency	134.5 dB	134.5 dB	134.5 dB
Driver Information			
Low-frequency	10"/3" voice coil woofer	12"/4" voice coil woofer	15"/4" voice coil woofer
High-frequency	3" diaphragm/1.4" exit	3" diaphragm/1.4" exit	3" diaphragm/1.4" exit
Dimensions (HWD) inches	12.1" x 14.7" x 24"	12.1" x 19.7" x 24"	13.1" x 21.7" x 26.1"
Dimensions (HWD) mm	307 mm x 373 mm x 610 mm	307 mm x 500 mm x 610 mm	333 mm x 551 mm x 663 mm
Net Weight (each)	60 lb / 27.2 kg	77 lb / 34.9 kg	86 lb / 39 kg

RoHS

QSC CSM monitors utilize a unique recessed connector pocket mounted on the bottom side of the enclosure, that with the use of its four corner rubber feet, enable the user to dress the cables in any direction needed (360°), while fully protecting the cable end connectors from damage or sight issues.



CSM drive rack: BASIS 922az, PL325 and PL380 amplifiers.



**NEW!**

## AcousticDesign™ Series Ceiling Loudspeakers

Installed Sound

### AD-C820/821

The AD-C820R/S and AD-C821R/S (R for Round Grille and S for Square Grille) loudspeaker systems are designed for systems requiring higher SPL output in a ceiling mounted loudspeaker. These loudspeakers continue the AD Series philosophy of bringing natural and accurate sound quality combined with versatility and reliability to high-ceiling applications.

Their 8" woofer features a treated paper cone mounted on a steel frame while optimized enclosures offer low frequency of the system down to 52 Hz. The 1.4" compression driver fires through the center of the woofer and is acoustically mated to the woofer for a smooth transition at crossover. Collectively, both transducers achieve a 90 degree axisymmetric nominal coverage.

High-current, low tolerance network components provide smooth full-range, passive performance. The included 70V/100V, custom designed transformer is optimized for low line loss as well as accurate and transparent acoustic performance.

The AD-C820R/S Systems ship with the AD-C800BB backcan and are perfect for pre-installed applications. The AD-C8201R/S Systems incorporate a fully integrated, factory sealed enclosure and use "dog-ear" style mounting - perfect for blind mount installations. AD-C8201R/S models also include a set of tile rails and C-rings to complete the installation.

The acoustically identical AD-C820R/S and AD-C821R/S loudspeakers measure 91dB sensitivity (1W/1m) and at full continuous power are capable of producing 114 dB SPL (1W/1m) output.

### AD-C1200

The AD-C1200 is designed for systems that require high-output, large format in-ceiling mounted loudspeakers. Utilizing custom designed transducers and crossover networks, in combination with an acoustically optimized enclosure, the AD-C1200 continues the AD Series philosophy to bring this same versatility and reliability to high-ceiling applications.

Each AD-C1200 includes the coaxial transducers, a transformer and a crossover network, factory mounted on a steel baffle. The baffle is designed to mount to the QSC enclosure (AD-C1200BB) or to any ~2.5 ft<sup>3</sup> enclosure using industry standard transducer / baffle mounting points. A square grille (AD-C1200SG) is available to finish the installation.

The 12" woofer is made with a treated paper cone on a steel frame. In the optimized enclosure, usable low frequency of the system extends down to 37 Hz. The 1.75" compression driver fires through the center of the woofer and is acoustically mated to the woofer for a smooth transition at the crossover. Collectively these transducers achieve an 85 degree axisymmetric nominal coverage.

High-current, low tolerance network components provide smooth full-range, passive performance. The included 70V/100V custom designed transformer is optimized for low line loss as well as accurate and transparent acoustic performance.

	<b>NEW!</b> AD-C820/C821	<b>NEW!</b> AD-C1200
System Type	2-way, ceiling / flush mounted, ported system	2-way, ceiling / flush mounted, ported system
Frequency Range (-10 dB)	52 Hz – 18 kHz	37 Hz – 18 kHz
Frequency Response (-6 dB)	61 Hz – 18 kHz	42 Hz – 18 kHz
Nominal Coverage	90° axisymmetric	85° axisymmetric
Full Range Power Capacity <sup>1</sup> Sensitivity <sup>2</sup> Peak SPL <sup>3</sup>	200 W (100 hrs) 91 dB 120 dB	300 W (100 hrs) 93 dB 124 dB
Driver Information LF	8" weather resistant, treated paper cone woofer	12" weather resistant, treated paper cone woofer, 75 mm voice coil, ferrite magnet
HF	1.4" co-axial compression driver	1.75" co-axial compression driver
Controls / Selectors	70 V: 100, 50, 25, 12.5 W 100 V: 100, 50, 25 W 16Ω Externally Selectable	70 V: 150, 75, 37.5 W 100 V: 150, 75, 37.5, 18.2 W 16Ω Internally Selectable
Input Connectors	AD-C820: Ceramic block AD-C821: 4-pin Euro terminals Fire protective sub-chamber	Ceramic block terminals Fire protective sub-chamber
Suspension / Attachment Point	AD-C820: Pre-installed back box with 4 mounting straps; AD-C821: Captive, integral mounting clamps	Pre-installed back box with 4 mounting tabs
Dimensions (HWD) inches	14.9" x 14.9" x 8.3"	23" x 18" x 15.5"
Dimensions (HWD) mm	379 mm x 379 mm x 211 mm	584 mm x 454 mm x 393 mm
Net Weight (each)	17.5 lb / 7.9 kg	78 lb / 35.3 kg

<sup>1</sup> Continuous IEC specified test signal, 2 hours unless otherwise stated.

<sup>2</sup> Based on nominal impedance, measured in full space. 1 W @ 1 m.

<sup>3</sup> Calculated using specified power capacity and system sensitivity. 6 dB peak-to-average signal ratio assumed.

RoHS

The AD-C1200 loudspeaker system measures 93dB sensitivity (1W/1m) and at full continuous power is capable of producing 118dB SPL (1W/1m) output.

#### Available AD-C Accessories

- ADC-MR4: Mud Ring Bracket for AD-C42T.
- ADC-NC4: New Construction Bracket for AD-C42T.
- ADC-MR: Mud Ring Bracket for AD-CI52T.
- ADC-NC: New Construction Bracket for AD-CI52T.
- ADC-MRS: Mud Ring Bracket for AD-CI52ST and AD-C820R/S & AD-C821R/S.
- ADC-NCS: New Construction Bracket for AD-CI52ST and AD-C820R/S & AD-C821R/S.





## AcousticDesign™ Series Ceiling Loudspeakers

### Installed Sound

The AcousticDesign™ Series is a line of installation loudspeakers designed for trouble-free operation and versatility in a wide variety of applications ranging from restaurants to retail and office spaces, houses of worship, convention centers and transportation settings. AcousticDesign loudspeakers offer natural and pleasing sound reproduction with very low distortion characteristics. The AD Series is comprised of two product categories, the AD-C (in-ceiling) loudspeakers and AD-S (surface mount) loudspeakers. Each is designed to provide seamless sonic integration with the other, allowing for mixed use in any installation.

AcousticDesign loudspeakers are supported in EASE Address systems providing designers the ability to quickly and easily develop simple designs and performance prediction for ceiling loudspeaker layout. Designers can download a copy of the EASE Address software from the QSC website at no charge.

### AD-C42T

Designed for background music and general purpose playback, the AD-C42T ceiling mount loudspeaker is ideal for installations where a small, minimally intrusive footprint is desired. Rated for 40 W continuous (160 W peak) power handling, the AD-C42T features a 4" polypropylene cone woofer combined with a 0.75" titanium diaphragm dome tweeter and offers 88 dB (1 W/1 m) sensitivity. The coaxial post is mounted slightly off center in the low frequency driver to minimize destructive interference and maintain smooth, 100° conical dispersion. For maximum flexibility, the AD-C42T also incorporates a 70/100V transformer with multiple taps plus an 8Ω bypass for low impedance operation.

The baffle and mounting tabs are molded from high-impact polystyrene while the rear, sealed enclosure is constructed from heavy gauge powder coated steel, optimized to deliver usable audio output below 70 Hz. The AD-C42T's fascia features an attractive aluminum grille backed with acoustically transparent cloth.

The input cup on the rear of the enclosure features a conduit attachment point with an additional knockout for daisy-chain wiring. The AD-C42T's high-temperature-resistant ceramic input screw terminal complies with European safety standards.

The AD-C42T ships complete with C-rings and tile rails; new construction rings (ADC-NC4) and mud rings (ADC-MR4) are available as options.

### AD-CI52T | AD-CI52ST

These high performance in-ceiling loudspeakers deliver accurate, high-fidelity sound for foreground/background music and paging systems alike. The AD-CI52ST large-ported enclosure offers extended low frequency response while its shallow depth is ideal for installations with limited mounting space. The AD-CI52T provides an even less-visually intrusive option and the unit is fully sealed. A weather-resistant 5.25" transducer with a fiberglass cone, 25 mm voice coil and rubber surround delivers the low frequencies in both models, while the high-frequencies are provided by a pure titanium 1" dome tweeter with a neodymium magnet.

AD-CI52T and AD-CI52ST feature a custom, low distortion, wide bandwidth transformer enabling both models to be used on either 70/100V lines. The transformer tap switch offers multiple output settings and includes an 8Ω bypass for low impedance operation.

The AD-CI52T | AD-CI52ST | models ship complete with C-rings and tile rails; new construction rings (ADC-NC4) and mud rings (ADC-MR4) are available as options.



	AD-C42T	AD-CI52T	AD-CI52ST	AD-C81Tw
System Type	2-way, ceiling / flush mounted, sealed system	2-way, ceiling / flush mounted, ported system	Shallow can, 2-way, ceiling / flush mounted, ported system	Subwoofer, ceiling / flush mounted, ported system
Frequency Range (-10 dB)	60 Hz – 20 kHz	65 Hz – 20 kHz	53 Hz – 20 kHz	28 Hz – 208 Hz
Frequency Response ( $\pm 3$ dB)	72 Hz – 20 kHz	85 Hz – 20 kHz	63 Hz – 20 kHz	39 Hz – 184 Hz
Nominal Coverage	100° conical	90° conical	100° conical	N/A
Full Range Power Capacity <sup>1</sup>	40 W (100 hrs)	40 W (100 hrs)	40 W (100 hrs)	100 W (100 hrs)
Sensitivity <sup>2</sup>	88 dB	86 dB	87.5 dB	92 dB
Peak SPL <sup>3</sup>	110 dB	108 dB	109 dB	118 dB
Driver Information LF	4" weather resistant, polypropylene cone woofer	5.25" weather resistant, low distortion fiberglass cone woofer, 25 mm voice coil, neodymium magnet	5.25" weather resistant, low distortion fiberglass cone woofer, 25 mm voice coil, neodymium magnet	8" weather resistant, polypropylene cone woofer, rubber surround
HF	0.75" titanium dome tweeter, rubber surround	1" titanium dome tweeter, rubber surround	1" titanium dome tweeter, rubber surround	N/A
Controls / Selectors	70 V: 30, 15, 7.5, 3.8 W 100 V: 30, 15, 7.5 W 8 $\Omega$ Externally Selectable	70 V: 30, 15, 7.5, 3.8 W 100 V: 30, 15, 7.5, 3.8 W 8 $\Omega$ Externally Selectable	70 V: 30, 15, 7.5, 3.8 W 100 V: 30, 15, 7.5, 3.8 W 8 $\Omega$ Externally Selectable	70 V: 60, 30, 15, 7.5 W 100 V: 60, 30, 15 W 8 $\Omega$ Externally Selectable
Input Connectors	Ceramic block or 4-pin Euro terminals, fire protective sub-chamber	4-pin Euro terminals, fire protective sub-chamber	4-pin Euro terminals, fire protective sub-chamber	Ceramic block or 4-pin Euro terminals, fire protective sub-chamber
Suspension / Attachment Point	N/A	N/A	N/A	N/A
Dimensions (HWD) inches	7.5" x 7.5" x 9.3"	8.5" x 8.5" x 9.3"	12.6" x 12.6" x 3.75"	12.6" x 12.6" x 14.8"
Dimensions (HWD) mm	191 mm x 191 mm x 236 mm	216 mm x 216 mm x 236 mm	321 mm x 321 mm x 95 mm	320 mm x 320 mm x 376 mm
Net Weight (each)	6.1 lb / 2.7 kg	7.5 lb / 3.4 kg	8 lb / 3.7 kg	20 lb / 9.1 kg

<sup>1</sup> Continuous IEC specified test signal, 2 hours unless otherwise stated.

<sup>2</sup> Based on nominal impedance, measured in full space. 1 W @ 1 m.

<sup>3</sup> Calculated using specified power capacity and system sensitivity. 6 dB peak-to-average signal ratio assumed.

RoHS

## AD-C81Tw

The AD-C81Tw ceiling mount subwoofer supplements AcousticDesign systems with low frequency extension that is acoustically ideal for both ceiling-mount and surface mount models. Rated for 100 W continuous (400 W peak) power handling, the AD-C81Tw extends low-frequency output below 40 Hz and has a 120 Hz low-pass filter that is switchable from the front panel. For maximum flexibility, the AD-C42T incorporates a 70/100 volt transformer with multiple taps plus an 8 $\Omega$  bypass for low impedance operation.

The unit's 8" woofer features a polypropylene cone with synthetic rubber surround. The driver works with the large port to provide solid low-frequency extension

without undesirable port turbulence. This highly efficient design offers 92dB (1 W/1 m) sensitivity.

The baffle and mounting tabs are molded from high-impact polystyrene while the enclosure is constructed from heavy gauge powder coated steel. For minimum vertical clearance, the input cup is on the side of the enclosure: it features a conduit attachment point, plus an additional knockout for daisy-chain wiring. The high temperature-resistant ceramic input screw terminal complies with European safety standards. The AD-C81Tw's fascia features an attractive aluminum grille backed with acoustically transparent cloth.

The AD-C81Tw ships complete with C-rings and tile rails; new construction rings (ADC-NCS) and mud rings (ADC-MRS) are available as options.

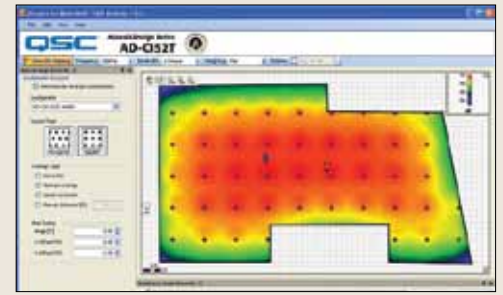

## EASE Address Software

This is free software that may be downloaded from the support section of the QSC website

EASE Address is a software that allows the modeling of acoustic sources, in particular distributed loudspeaker systems, in two dimensions. It allows the system designer to quickly develop a simple design for a ceiling loudspeaker system, while also allowing the easy and quick prediction of the system performance in a given hall.



## AcousticDesign™ Series Loudspeakers

Installed Sound



### AD-S32T

Designed for background and general purpose audio playback, the AD-S32T surface mount loudspeaker is acoustically matched with both ceiling and surface mount speakers in the AcousticDesign Series. Full sounding and fully featured in a surprisingly small package, the AD-S32T has 85 dB sensitivity, 30 watts continuous power handling and can handle 120 watt peaks.

The 3" woofer has a polypropylene cone and synthetic rubber surround for reliable operation in high humidity. It is optimized to deliver useable output below 70 Hz. The humbucking magnet structure can be used next to CRT monitors without interference. The 0.75" dome tweeter has a titanium diaphragm and a cloth surround. The waveguide provides 100° by 100° dispersion.

The attractive, compact enclosure is molded from highimpact polystyrene, and like all the AcousticDesign Series loudspeakers, is available in black or white and can be painted to match any specific décor. An aluminum grille backed with acoustically transparent foam protects the components from the elements. For outdoor applications, the plated screw input signal terminals can be sealed with the included weather cover. A wide bandwidth transformer with multiple power taps for either 70 volt or 100 volt lines and a bypass switch for 8 ohm operation is part of the AD-S32T system. A versatile ball mount assembly and yoke mount, both included, simplify installation.

### AD-S52 | S52T

The AD-S52 is designed for flat, full-range output: ideal for background/foreground music, paging, secondary coverage in live performance venues, or

anywhere accurate reproduction and audio quality are key requirements. Sleek, contemporary styling blends easily into hotels, restaurants, sports bars, convention facilities, and multimedia environments.

The AD-S52 high-output, 2-way design includes a 5.25" weatherproof, low-frequency transducer with magnetic shielding for use next to CRT monitors, along with a 1" neodymium tweeter. Dynamic power protection incorporated into the crossover network protects the system against accidental overloads. The AD-S52T includes a 70/100 volt matching transformer for distributed systems. A rear panel switch selects the power level: it can also bypass the transformer completely for 8Ω operation, providing greater flexibility than many competing products.

The AD-S52 system includes a ball-mount assembly for convenient installation in a wide variety of orientations. The ball mount adapter's back plate can be removed to reduce the overall depth of the assembly and the footprint of the wall mount. A weather-resistant, input connection cover protects the input terminals.

#### Available AD-S52 | S52T Accessories

- YM-5 Yoke Mount

### AD-S82 | S82H

When higher acoustic output is called for, the full-range AD-S82 and AD-S82H surface mount loudspeakers are the choice for background/foreground music and paging applications that require accurate reproduction and audio quality. Their flat response also makes them ideal for secondary coverage in live performance facilities. Sleek, contemporary, yet unobtrusive styling meets the needs of multiple venues including hotels, restaurants,

	AD-S32T	AD-S52	AD-S52T	AD-S82 (standard output)	AD-S82H (high output)	AD-S282H	AD-S282HT
System Type	Compact 2-way, surface mount, ported loudspeaker system	Compact 2-way, surface mount, ported loudspeaker system	Compact 2-way, surface mount, ported loudspeaker system	Compact 2-way, surface mount, ported loudspeaker system	Compact 2-way, surface mount, ported loudspeaker system	Compact 2-way, surface mount, ported loudspeaker system	Compact 2-way, surface mount, ported loudspeaker system
Frequency Range (-10 dB)	65 Hz – 20 Hz	60 Hz – 20 kHz	60 Hz – 20 kHz	65 Hz – 19 kHz	60 Hz – 22 kHz	60 Hz – 29.5 kHz	60 Hz – 29.5 kHz
Frequency Response (±3 dB)	73 Hz – 20 kHz	75 Hz – 19 kHz	75 Hz – 19 kHz	85 Hz – 18 kHz	80 Hz – 21 kHz	80 Hz – 27.7 kHz	80 Hz – 27.7 kHz
Nominal Coverage	100°H x 100°V	90°H x 90°V	90°H x 90°V	90°H x 60°V (rotatable)	90°H x 60°V (rotatable)	90°H x 60°V	90°H x 60°V
Full Range							
Power Capacity <sup>1</sup>	30 W (100 hrs)	60 W (100 hrs)	60 W (100 hrs)	110 W (8 hrs)	240 W (8 hrs)	450 W (8 hrs)	450 W (8 hrs)
Sensitivity <sup>2</sup>	85 dB	86.5 dB	86 dB	90.5 dB	90.5 dB	93 dB	93 dB
Peak SPL <sup>3</sup>	105 dB	110 dB	107 dB	117 dB	120 dB	125 dB	125 dB
Driver Information							
LF	3" weather resistant, polypropylene cone woofer	5.25" shielded, weather-resistant	5.25" shielded, weather-resistant	8" fiberglass cone, 1 1/4" voice coil	8" high-power treated paper cone, 2" voice coil, neodymium magnet	8" high-power treated paper cone x 2, 2" voice coil, neodymium magnet	8" high-power treated paper cone x 2, 2" voice coil, neodymium magnet
HF	0.75" neodymium tweeter	1" neodymium tweeter	1" neodymium tweeter	1" titanium dome tweeter, neodymium magnet	1" high output compression driver	1" high output compression driver	1" high output compression driver
Controls / Selectors	70 V: 30, 15, 7.5, 3.8 W 100 V: 30, 15, 7.5 W 8Ω Selectable Rotary Knob	N/A	70 V: 30, 15, 7.5 3.75 W 100 V: 30, 15, 7.5 W 8Ω Selectable Rotary Knob	N/A	N/A	N/A	70 V: 200, 100, 25, 20 W 100 V: 200, 100, 50 W 8Ω Externally Selectable
Input Connectors	Screw terminals	5-way binding posts x 2	5-way binding posts x 2	Concealed 5-way binding posts x 2, IntelliDock mounting/connection system	Concealed 5-way binding posts x 2, IntelliDock mounting/connection system	Barrier Strip (switchable: passive/active)	Barrier Strip
Suspension / Attachment Point	N/A	N/A	N/A	N/A	N/A	OmniMount Pro60.0 Attachment	OmniMount Pro60.0 Attachment
Dimensions (HWD) inches	7.9" x 4.8" x 5.5"	11.3" x 7.0" x 8.3"	11.3" x 7.0" x 8.3"	17.4" x 10.0" x 11.2"	17.4" x 10.0" x 11.2"	26.2" x 10.2" x 11.4"	26.2" x 10.2" x 11.4"
Dimensions (HWD) mm	201 mm x 122 mm x 140 mm	287 mm x 178 mm x 212 mm	287 mm x 178 mm x 212 mm	445 mm x 255 mm x 285 mm	445 mm x 255 mm x 285 mm	445 mm x 255 mm x 285 mm	445 mm x 255 mm x 285 mm
Weight (each)	4 lb / 1.8 kg	15 lb / 6.8 kg	18 lb / 8.2 kg	16.9 lb / 7.4 kg	16.2 lb / 7.7 kg	27.7 lb / 12.6 kg	27.7 lb / 12.6 kg

<sup>1</sup> Continuous IEC specified test signal, 2 hours unless otherwise stated.

<sup>2</sup> Based on nominal impedance, measured in full space. 1 W @ 1 m.

<sup>3</sup> Calculated using specified power capacity and system sensitivity. 6 dB peak-to-average signal ratio assumed.

RoHS

sports bars, convention facilities, and multimedia environments. Its magnetically shielded low-frequency driver is suitable for use near CRT monitors.

The AD-S82 is a 2-way system housed in a weather resistant, ported enclosure made from injection-molded, high-impact polystyrene. The low-frequency transducer is an 8" weatherproof driver with a heavy-duty double-roll cloth surround. For applications requiring higher power handling and acoustic output, the ADS82H (High Output) replaces the 1" titanium dome tweeter used in the AD-S82 with a 1" exit compression driver. Both models use a 90° x 60° version of QSC's patented, rotatable Advanced Directivity™ waveguide. Both are available with or without a 70/100 volt transformer.

QSC's IntelliDock™ intelligent mounting system sets a new standard for ease of installation and security. The IntelliDock system includes everything necessary to mount, wire, and position the speaker. A single step locks the speaker securely onto the docking station

while simultaneously making electrical connections. This unique and innovative design reduces installation time and wiring, while decreasing the risk of theft. Four mounting configurations are available, including a standard yoke mount.

#### Available AD-S82 Mounting Accessories

- ID-8 | ID-8T IntelliDock
- YM-8 | YM-8T Yoke Mount

#### AD-S282H | S282HT

When additional low-frequency performance and higher acoustical output are required, choose the dual-8" AD-S282H with 1" exit compression driver. For mounting flexibility, a yoke bracket is included. The AD-S282HT includes a 70/100 volt transformer for distributed systems. A rear panel switch selects the power level or bypasses the transformer for 8Ω operation, providing greater flexibility than many competing products.



**NEW!** **AcousticDesign™ Subwoofer**

Installed Sound



**AD-S28Tw**

The AD-S28Tw is acoustically matched to the entire AD Series and is designed to supplement audio systems by adding low-frequency extension. Rated for 250 watts continuous power handling and able to take up to 700 watt peaks, the AD-S28Tw is a great complement to any of the ceiling-mount or surface-mount AD Series models.

The dual 8" woofers are equipped with polypropylene cones for protection in humid environments. The bandpass enclosure features two chambers. One chamber is completely sealed, while the other chamber features a large port. The bandpass design allows for tight precise bass with extension down to 36 Hz. This highly efficient design produces a 1W at 1m sensitivity of 94 dB SPL. The AD-S28Tw has a built-in passive low-pass filter set at 120 Hz.

The marine grade plywood enclosure is built to the highest standard to provide exceptional resistance to high humidity. The zinc-plated steel grille has a black foam backing, molded ABS endcaps and a rotatable logo. On the rear of the enclosure is the input cup with a hinged door to conceal the controls and input connections. Input and output nickel plated screw terminals accept wiring from 18 AWG (1.02 mm<sup>2</sup>) to 12 AWG (2.053 mm<sup>2</sup>). Two rotary switches can be found in the input cup. One switch selects between the 70/100 volt transformer taps, while the other switch enables or disables the internal passive low-pass filter.

The AD-S28Tw can be deployed in a number of ways. With the included rubber feet attached, the subwoofer can be floor or shelf-standing. Suspended installation is available with either the included forged-shoulder eyebolts and accessories or the included steel yoke.

AD-S28Tw	
System Type	Surface mount bandpass subwoofer, ported
Low-frequency Transducer	Dual 8" (200 mm) weather resistant, polypropylene cone woofers, rubber surround
Frequency Range <sup>1</sup>	
Frequency Response (-6 dB)	42 Hz – 165 Hz
Useable Frequency Range (-10 dB)	36 Hz – 205 Hz
Filter	120 Hz low-pass, passive, bypassable
Maximum Output <sup>2</sup>	
Calculated Peak / Continuous Output 2π (half space) 4π (full space)	124 dB SPL / 118 dB SPL 118 dB SPL / 112 dB SPL
Nominal Impedance	8Ω
Power Rating	
RMS Power Handling <sup>3</sup>	250 W (2 hours IEC)
Recommended Max Amp Power	500 W RMS
Sensitivity	94 dB, 2.83 V, 1 m, half space (2π)
Transformers	
Type	Custom low distortion laminated core, wide bandwidth design
Taps	70 V: 200, 100, 50, 25 W / 100 V: 200, 100, 50 W / 8Ω selected by switch
Environmental	Exceeds Mil Spec 810 for humidity, salt spray and dust; IEC 60529 IP-X4 splash rating
Connectors	4 position barrier strip; 2 in / 2 out
Dimensions (HWD) inches	15.9" x 9.9" x 22.75"
Dimensions (HWD) mm	404 mm x 251 mm x 603 mm
Weight	43 lb / 19.5 kg

<sup>1</sup> All frequency ranges specified refer to measured free field response.  
<sup>2</sup> Calculated SPL at 1m, speaker operating at rated RMS power with pink noise within specified frequency range.  
<sup>3</sup> Maximum input power tested in accordance with IEC 268-5 recommendations, 50 Hz – 20 kHz band limiting, 6 dB signal crest factor.





## Distributed System

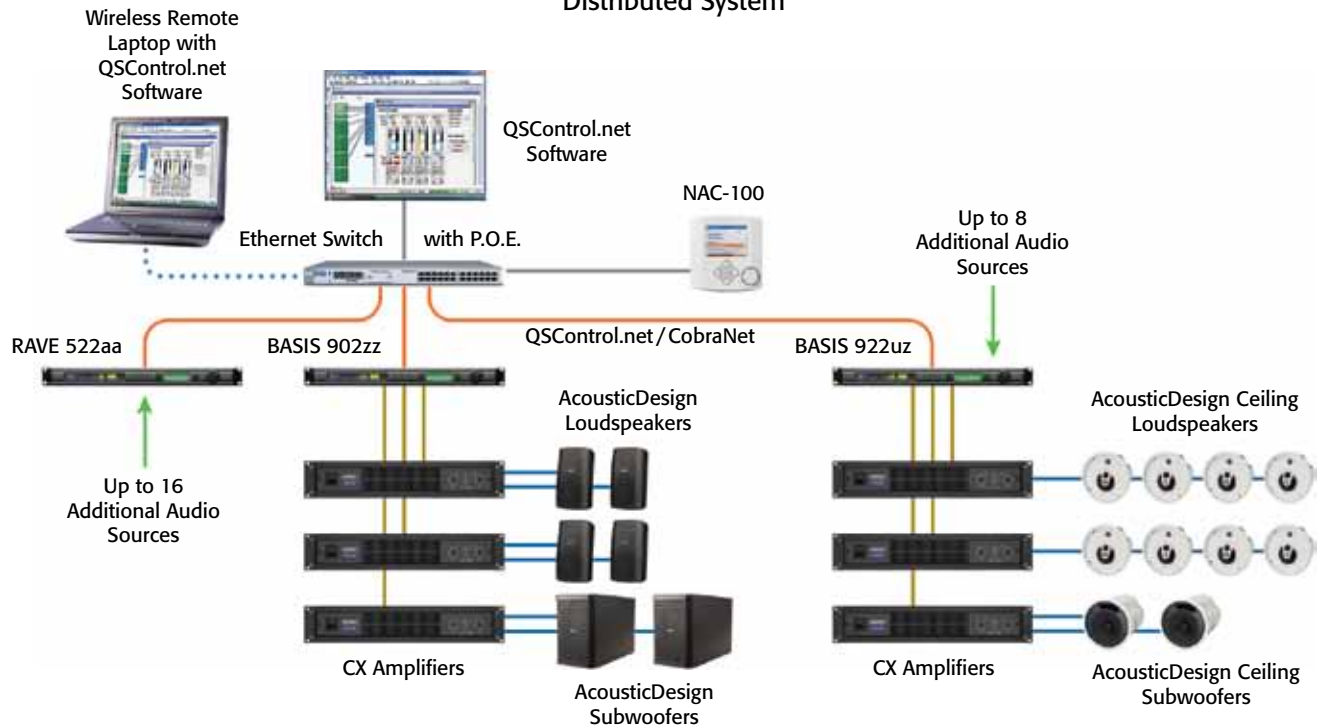

## Distributed System Solutions

In facilities ranging from hospitality to houses of worship to themed attractions, QControl.net™ version 3 is capable of managing an entire venue's digital audio routing and processing requirements. The new NAC-100 wall controller may be programmed to perform a broad range of simple or complex system control tasks.

A growing selection of AcousticDesign™ ceiling and surface mount loudspeakers powered by the respected CX Series amplifiers give system designers and installers the reliability and accurate reproduction they're looking for.

Facility owners and system designers are increasingly recognizing the need for subwoofers in background and foreground music systems. Extended low-frequencies bring power and energy to the music without excessive overall level that can annoy customers and intrude on conversation. Our system example uses the new AcousticDesign AD-S28Tw surface mount subwoofer as well as the AD-C81Tw ceiling subwoofer. Consider adding subwoofers to your next high-quality music installation. You and your customers will thank you for it.



## ISIS Series Loudspeakers

Entertainers | Musicians | DJs  
Concert Systems

### I-82H

The QSC I-82H is an 8", 2-way, full-range loudspeaker that is well suited to applications in which low to moderate levels and very high-quality sound reinforcement are required. With the ability to be pole and mic stand mounted, truss mounted, or used as a floor monitor/stage fill, these injection molded speakers are an excellent choice for musicians, mobile entertainers, and others needing a high-quality, lightweight SR package that sounds great, is visually unobtrusive, and is easy to transport.

The I-82H enclosure incorporates an 8" weatherproof, LF transducer and a 1" exit HF compression driver. Dynamic Protection circuitry is included in the network to protect the HF driver from overload damage. The HF driver is coupled with QSC's unique Advanced Directivity™ rotatable waveguide — enabling the loudspeaker to deliver well-controlled coverage, regardless of its orientation.



An ideal solution for a variety of mobile SR applications, the I-82H includes a pole cup bracket for pole mount applications as well as a 5/8"-27 mic stand adapter. With the addition of QSC's optional I-YM8 Yoke Mount/Floor Monitor Kit, the I-82H can be horizontally pole mounted for pan and tilt aiming or used as a floor monitor. For truss mounting, the I-YM8 accepts most industry standard truss clamps.

#### I-82H Accessories Included

- Pole cup bracket
- Mic stand adapter

#### Optional I-82H Accessories

- I-YM8 Yoke Mount/Floor Monitor Kit





## I-282H

The QSC I-282H is a dual 8", 2-way, full-range loudspeaker that is well suited to applications in which moderate levels and very high-quality sound reinforcement are required. Pole mounted, truss mounted, or used as a floor monitor/stage fill, these injection molded speakers are an excellent choice for musicians, mobile entertainers, and anyone else needing a high-quality, lightweight SR package that sounds superb, is visually unobtrusive, and with its built-in handles, is easy to transport.

The I-282H enclosure incorporates two 8" weather resistant, LF transducers and a 1" exit HF compression driver. Bi-amplified or full-range operation may be selected by means of a rear-panel switch. The HF driver is coupled with QSC's unique Advanced Directivity™ rotatable waveguide – enabling the loudspeaker to deliver well-controlled coverage, regardless of its orientation.

An ideal solution for a variety of mobile SR applications, the I-282H includes a cup for pole mounting. By using the included yoke mount with swivel extension feet, the I-282-H can be vertically or horizontally mounted for pan and tilt focusing or used as a floor monitor. For truss mounting, the yoke accepts most industry standard truss clamps.

### I-282H Accessories Included

- Yoke Mount

	I-82H	I-282H
System Type	Compact 2-way, ported enclosure	Compact 2-way, ported enclosure
Frequency Range (-10 dB)	60 Hz – 22 kHz	60 Hz – 29.5 kHz
Frequency Response (-6 dB)	80 Hz – 21 kHz	80 Hz – 27.7 kHz
Nominal Coverage	90°H x 60°V (rotatable)	90°H x 60°V (rotatable)
Power Capacity <sup>1</sup> / Sensitivity <sup>2</sup> / Peak SPL <sup>3</sup>		
Full Range	240 W (8 hrs) / 90.5 dB / 120 dB	450 W (8 hrs) / 93 dB / 126 dB
Driver Information LF	8" high power treated paper cone, 2" voice coil, neodymium magnet	8" high power treated paper cone x 2, 2" voice coil, neodymium magnet
Driver Information HF	1" exit compression driver	1" exit compression driver, 1.7" voice coil
Input Connectors	NL4 in parallel x 2	NL4 in parallel x 2
Suspension / Attachment Point	Yoke mount optional, pole mount socket, mike stand adapter included	Yoke mount, pole mount socket, mike stand adapter included
Dimensions (HWD) inches	17.4" x 10" x 11.2"	26.17" x 11.44" x 10.21"
Dimensions (HWD) mm	442.0 mm x 254 mm x 284.5 mm	561 mm x 686 mm x 768 mm
Net Weight (each)	17.5 lb / 7.9 kg	28.5 lb / 12.9 kg

<sup>1</sup> Continuous IEC specified test signal, 2 hours unless otherwise stated.

<sup>2</sup> Based on nominal impedance, measured in full space. 1 W @ 1 m.

<sup>3</sup> Calculated using specified power capacity and system sensitivity.

<sup>4</sup> 6 dB peak-to-average signal ratio assumed.

RoHS

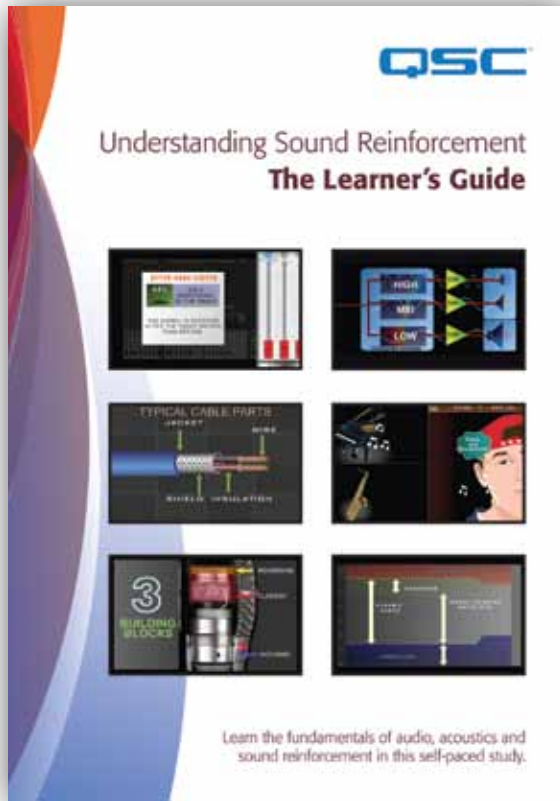

## Understanding Sound Reinforcement, The Learner's Guide

Sound Engineers | Musicians | DJs

Understanding the fundamentals of audio, acoustics and sound reinforcement can be challenging to the first-time learner. In this self-paced course, this knowledge is presented through narration, images and animation in a concise and easy-to-follow manner. Whether the learner is an individual Sound Engineer, Musician or DJ or a member of a House of Worship, School, Public Facility, Community Organization or Private Enterprise or simply anyone with an interest in live sound, this program promises to deliver a comprehensive and practical education that will be of real and lasting value.

### Learning Applications Included in the Program:

- Sound & Hearing
- Signal Path & Gain Structure
- Mixing Consoles
- Equalization
- Acoustics
- Microphones
- Signal Processors
- Power Amplifiers
- Loudspeakers
- Cables, Connectors & Impedance

### Additional Information:

- Plays on DVD-equipped PC and Mac computers as well as standard DVD and Blu-Ray players
- Contains both English and Spanish narrations
- Updated graphics bring the course material to life
- Program also includes chapter quizzes available online, free with product registration at [www.qscaudio.com](http://www.qscaudio.com).



## Main Contacts

### SALES

Greg McLagan  
Vice President, Global Sales  
greg\_mclagan@qscaudio.com  
(714) 957-7170

### International

Shawn Watts  
Sr. Director, International Sales & Global Education  
shawn\_watts@qscaudio.com  
(714) 327-4637

Manolo Yanes  
Sales Manager, Latin America  
Manolo@qscaudio.com  
(714) 276-4932

Mark Bailey  
Sales Manager, EMEA  
mark.bailey@qscaudio.com  
+44 7921 021319

### U.S. Domestic

Perry Celia  
Director, U.S. Sales - Western Region  
perry\_celia@qscaudio.com  
(714) 668-7219

Mark Healy  
Director, U.S. Sales – Eastern Region  
mark\_healy@qscaudio.com  
(714) 327-4620

### Q-Sys™

Scott Kalarchik  
Director, Engineered Systems  
scott\_kalarchik@qscaudio.com  
(714) 957-7126

### MARKETING

Gerry Tschetter  
Vice President, Marketing  
gerry\_tschetter@qscaudio.com  
(714) 327-4619

David Fuller  
Director, Technical Marketing  
david.fuller@qscaudio.com  
(714) 688-7222

Ray van Straten  
Director, Marketing Communications  
ray\_vanstraten@qscaudio.com  
(714) 327-4634

### TECHNICAL SERVICES

Paul Dinneweth,  
Service Engineering Manager  
paul\_dinneweth@qscaudio.com  
(714) 327-4671

Tracey Homan  
Systems Engineering Manager  
tracey\_homan@qscaudio.com  
(714) 327-4670

Susan Tolson  
Customer Care Manager  
susan\_tolson@qscaudio.com  
(714) 327-4651

A close-up, low-angle shot of a black QSC KW Series speaker. The speaker's grille is a fine, dark mesh. A small, glowing blue LED light is visible on the lower left side of the speaker's frame. In the background, a blurred live music venue is visible, featuring a red drum set and a cymbal stand. The lighting is warm and focused on the speaker.

**QSC**  
KW SERIES



Passionate About Sound



[qscaudio.com](http://qscaudio.com)

1-800-854-4079 or 714-957-7100  
Outside the U.S. +1-714-754-6175

Fax: 714-754-6174

QSC Audio Products, LLC  
1675 MacArthur Boulevard  
Costa Mesa, CA 92626



This catalog is printed with Forest Stewardship Council™ certified paper and printing, using low VOC biodegradable soy inks and U.S. made paper.

please recycle



010711 ©2011 QSC Audio Products, LLC. All rights reserved. QSC, the QSC logo, PowerLight, WideLine, Q-Sys, QSCControl.net and BASIS are registered trademarks of QSC Audio Products, LLC, in the US and other countries. SOLO, ArQ, Tilt-Direct, GuardRail, DEEP, DMT, ModularDesign, AcousticDesign, IntelliDock, Advanced Directivity, Advanced Thermal Management and Intrinsic Correction are trademarks of QSC Audio Products, LLC. CobraNet is a trademark of Cirrus Logic. PowerCON and Speakon are trademarks of Neutrik. All trademarks are the property of their respective owners. Multiple aperture diffraction slot waveguide US Patent number 7177437. Other patents may apply or be pending.